

VISTA-10SE

Security System

Installation and Setup Guide

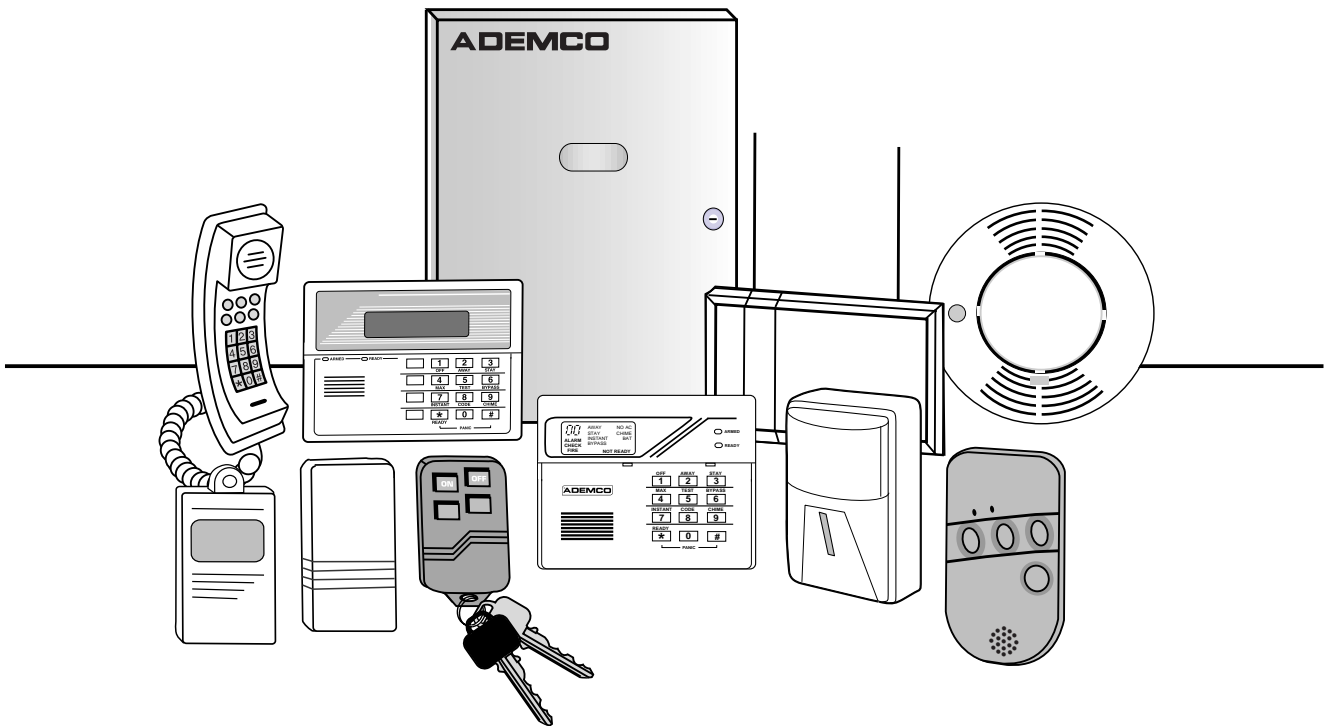

® ADEMCO

RECOMMENDATIONS FOR PROPER PROTECTION

The following recommendations for the location of fire and burglary detection devices help provide proper coverage for the protected premises.

Recommendations for Smoke and Heat Detectors

With regard to the number and placement of smoke/heat detectors, we subscribe to the recommendations contained in the National Fire Protection Association's (NFPA) Standard #72 noted below.

Early-warning fire detection is best achieved by the installation of fire detection equipment in all rooms and areas of the household as follows: For minimum protection, a smoke detector should be installed outside of each separate sleeping area, and on each additional floor of a multi-floor family living unit, including basements. The installation of **smoke detectors** in kitchens, attics (finished or unfinished), or in garages is not normally recommended.

For maximum protection, the NFPA recommends that you install **heat** or **smoke detectors** in the living room, dining room, bedroom(s), kitchen, hallway(s), attic, furnace room, utility and storage rooms, basements and attached garages.

In addition, we recommend the following:

- Install a smoke detector inside every bedroom where a smoker sleeps.
- Install a smoke detector inside every bedroom where someone sleeps with the door partly or completely closed. Smoke could be blocked by the closed door. Also, an alarm in the hallway outside may not wake up the sleeper if the door is closed.
- Install a smoke detector inside bedrooms where electrical appliances (such as portable heaters, air conditioners, or humidifiers) are used.
- Install a smoke detector at both ends of a hallway if the hallway is more than 40 feet (12 meters) long.
- Install smoke detectors in any room where an alarm control is located, or in any room where alarm control connections to an AC source or phone lines are made. If detectors are not so located, a fire within the room could prevent the control from reporting a fire or an intrusion.

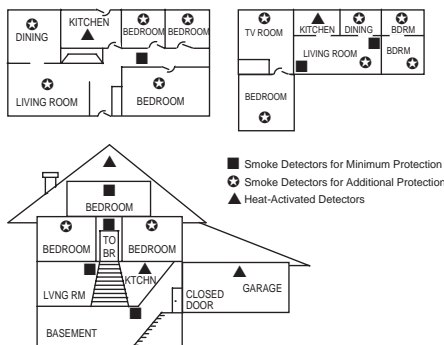

THIS CONTROL COMPLIES WITH NFPA REQUIREMENTS FOR TEMPORAL PULSE SOUNDING FOR FIRE NOTIFICATION APPLIANCES.

Recommendations for Proper Intrusion Protection

For proper intrusion coverage, sensors should be located at every possible point of entry to a home or commercial premises. This would include any skylights that may be present, and the upper windows in a multi-level building.

In addition, we recommend that radio backup be used in a security system so that alarm signals can still be sent to the alarm monitoring station in the event that the telephone lines are out of order (alarm signals are normally sent over the phone lines, if connected to an alarm monitoring station).

Table of Contents

SECTION 1. Introduction.....	1-1
Description	1-1
Features.....	1-1
SECTION 2. Installing the Control	2-1
Mounting the Cabinet	2-1
Installing the Lock (if used)	2-1
Mounting the Control's Circuit Board Alone in the Cabinet	2-2
Mounting the Control and RF Receiver Circuit Boards Together	2-2
Standard Phone Line Connections	2-3
SECTION 3. Installing Remote Keypads	3-1
Keypads That May Be Used.....	3-1
Wiring to the Keypads.....	3-1
Mounting the Keypads	3-2
Supplementary Power for Additional Keypads	3-2
Preliminary Checkout Procedure	3-3
SECTION 4. Basic Hardwired Zones 1-6	4-1
Installing the Hardwired Zones.....	4-1
Programming Hardwired Zones	4-2
SECTION 5. Wireless Expansion (5800 System)	5-1
About Wireless Expansion	5-1
Installing the 5881/5882 Receiver	5-2
Installing the 5800TM Module	5-3
About Jam Detection and Reporting	5-3
5800 Series Transmitters	5-3
Installing 5800 Series Transmitters.....	5-6
SECTION 6. Relay Output Devices	6-1
Relay Device Basics	6-1
4204 Relay Modules.....	6-1
Programming Options	6-2
SECTION 7. 4285 and 4286 VIP Module	7-1
Installing the (Voice Interactive Phone) Module.....	7-1
Programming the Control for Phone Access	7-4
Checking the Operation of the VIP Module.....	7-4
SECTION 8. External Sounders.....	8-1
Compatible Sounders.....	8-1
Sounder Connections and Power	8-2
SECTION 9. Long-Range Radio	9-1
About Long-Range Radio.....	9-1
Programming for Long-Range Radio.....	9-1
Dynamic Signaling Feature	9-2
SECTION 10. Audio Alarm Verification (AAV) Unit.....	10-1
About Audio Alarm Verification	10-1

SECTION 11. Final Power-Up	11-1
Earth Ground Connections	11-1
Wiring the AC Transformer	11-1
AC Power-Up	11-2
Calculating the Battery Size Needed	11-2
Connecting the Backup Battery.....	11-3
SECTION 12. Mechanics of Programming	12-1
About Programming	12-1
Entering the Program Mode	12-1
SECTION 13. Zone Response Type Definitions	13-1
Zone Type Definitions.....	13-1
SECTION 14. Data Field Descriptions	14-1
Descriptions of System Data Fields.....	14-1
SECTION 15. Zone Programming.....	15-1
About Zone Programming	15-1
SECTION 16. Output Device Programming.....	16-1
Programming Options Defined	16-1
Programming Output Relays	16-3
SECTION 17. Zone Lists	17-1
SECTION 18. Alpha Descriptor Programming	18-1
About Alpha Descriptor Programming.....	18-1
Zone Descriptors.....	18-1
SECTION 19. Remote Programming and Control (Downloading).....	19-1
SECTION 20. System Communication	20-1
Panel Communication with Central Station.....	20-1
Report Code Formats.....	20-1
Table of Contact ID Event Codes.....	20-2
SECTION 21. System Operation	21-1
Security Codes	21-1
Keypad Functions.....	21-2
Trouble Conditions	21-4
SECTION 22. Testing the System	22-1
Test Procedure	22-1
SECTION 23. Specifications & Accessories	23-1
Specifications	23-1
Accessories (Compatible Devices).....	23-2
APPENDIX A REGULATORY AGENCY STATEMENTS	A-1
APPENDIX B Limitations and Warranties.....	B-1
Programming Form	Insert

Introduction

In This Section

◆ *Description*

◆ *Features*

Description

The VISTA-10SE is a control that supports up to 22 hardwired and wireless zones, plus remote keypads.

Features

Basic Hardwired Zones

Provides 6 basic hardwired zones having the following characteristics:

- Zones 1-6 response time is 300–500 milliseconds.
- Zone 3 programmable fast response time is 10–15 milliseconds.
- EOLR supervision supporting N.O. or N.C. sensors
- Zone 5 supports as many 4-wire smoke or heat detectors as can be powered from the control).
- Zones 7, 95, and 96 are keypad Panics.
- Zone 8 is Duress.
- Zone 9 is Tamper.

Optional Expansion Zones

Wireless Expansion:

- Supports up to 16 wireless zones.
- Requires the use of a 5881 (5882 in Canada) type RF receiver (with 5800 Series wireless transmitters), as shown below.

<u>Receiver Model</u>	<u>No. of Zones</u>	<u>Transmitter Type</u>
5881L (5882L*)	Up to 8	5800
5881M (5881M*)	Up to 16	5800
5881H (5882H*)	Up to 16	5800

* Used in Canada.

Remote Keypads

Up to 4 of any of the following keypads may be used:

Fixed-Word Keypads: **6127***, **6128**, and **6137**.

* This keypad cannot be used if a 4285/4286 VIP Module is being used.

Alpha Keypads **6139** (2-line **alphanumeric** display).

6138 (1-line **alphanumeric** display).



When programming from a keypad, a 6139 2-line alpha keypad must be connected (but need not stay in the system).

Security Codes

- One Master code for entire system (User 2). Installer code is User 1.
- 4 secondary user codes (Users 3–6).
- One duress code (User 8).



Duress Code: An emergency code that, when used to disarm or arm the system, will send a silent duress message to the central station.

Keypad Panic Keys

- Up to 3 programmable panic key functions are provided.
- Designated as Zones 7, 95, 96.
- Activated by wired and wireless keypads.
- Reported separately.

Paging Feature

If the paging feature has been programmed for your system, your pager will respond to certain conditions as they occur in your system, and display code numbers indicating the type of condition that has occurred.

Quick Arm Feature

“Quick Arm” may be programmed, allowing use of the [#] key in place of the security code for arming (Quick Arm will not work unless the Master code has been programmed into the system).

Optional Bell Supervision

This is a hardware-enabled option, achieved by cutting a red jumper on the PC board. If the “Alarm Output” loop connected to an external sounder is then opened or shorted, a “bell trouble” message will be displayed at the touchpads, accompanied by a trouble sound. A trouble report will also be sent to the central station.

Optional RF Jam Detection for 5800 Wireless Systems

If RF jam detection is programmed for a 5800 RF system, the RF receiver will detect a condition that may impede proper RF reception (i.e., jamming or other RF interference). Such a condition will produce a message display, and a report will be sent to the central monitoring station (if trouble reporting is enabled).

Optional Output Relays

- Up to 4 relays using one **4204 Relay Module**.
- Actions programmable to respond to zone activity or manual keypad entries.

Optional VIP Module

- Supports the ADEMCO **4285/4286 VIP Module**.
- Provides access to the system via on-premises or off-premises phones for arming, disarming, etc., plus control of relay outputs.

Optional Long-Range Radio

Allows all messages that have been programmed to go to the primary telephone number to be reported additionally to a 7720 PLUS or 7820 radio.

Alarm Output

- Provides a 12VDC, 2 AMP output that can drive the compatible sounders listed in the EXTERNAL SOUNDERS section (assumes a fully charged battery is connected).
- Steady output for burglary/panic, or temporal pulse sounding output for fire notification, as required by UL.
- Uses current-limiting circuitry for protection.

Auxiliary Power Output

- Provides 12VDC, 500mA maximum. Uses current limiting circuitry for protection.
- This output interrupts for smoke detector reset if 4-wire smoke detectors are used.

Programming

- Programmed options are stored in electrically erasable, nonvolatile EEPROM memory (information can be reprogrammed at any time and will not be lost in the event of a power loss).
- The system can be uploaded, downloaded, or controlled via an IBM-compatible computer, using ADEMCO's *Compass* Windows downloading software, and a modem specified by ADEMCO.

Keypad programming consists of:

- Data field programming.
- Interactive (menu) mode programming.



For programming from a keypad, a 6139 2-line alpha keypad must be connected (but need not stay in the system).

Communication Formats Supported

- ADEMCO Low Speed (Standard or Expanded)
- SESCOA/Radionics (Standard or Expanded)
- ADEMCO Express
- ADEMCO Contact ID

Zone Descriptors

You can assign alpha descriptors to all zones (useful only when using alpha keypads and/or the 4285/4286 VIP Module).

AC Power Supply

Uses No. 1321, 120VAC plug-in transformer with 16.5VAC 25VA output (1321CN in Canada).

Backup Battery

Rechargeable (Sealed Lead Acid) 12VDC, 4AH minimum.

Installing the Control

In This Section

- ◆ Mounting the Cabinet
- ◆ Installing the Lock
- ◆ Mounting the Control's Circuit Board Alone in the Cabinet
- ◆ Mounting the Control and RF Receiver Circuit Board in the Cabinet
- ◆ Standard Phone Line Connections

Mounting the Cabinet

Mount the control cabinet to a sturdy wall using fasteners or anchors (not supplied), in a clean, dry area that is not readily accessible to the general public. Four mounting holes are provided at the back of the cabinet for this purpose.

If an RF receiver is being used and you intend to mount its PC board within the cabinet, note the following:

- Do not mount the cabinet on or near metal objects. This will decrease RF range and/or block RF transmissions from wireless transmitters.
- Do not locate the cabinet in an area of high RF interference (revealed by frequent or prolonged lighting of the LED in the receiver after it is operational). Random flicker is OK.

Installing the Lock

Use an ADEMCO No. N6277 Cam Lock and No. N6277-1 Push-On Clip (Retainer Clip).

NOTE: The cabinet can be closed and secured *without* a lock by using 2 screws in the cover's edge.

1. Remove the cabinet door. *It is easily removable for servicing and is easily re-installed.*
2. Remove the lock knockout from the control cabinet door. Insert the key into the lock. Position the lock in the hole, making certain that the latch will make contact with the latch bracket when the door is closed.
3. Hold the lock steady, and insert the retainer clip into the retainer slots. Position the clip as illustrated in order to permit easy removal.

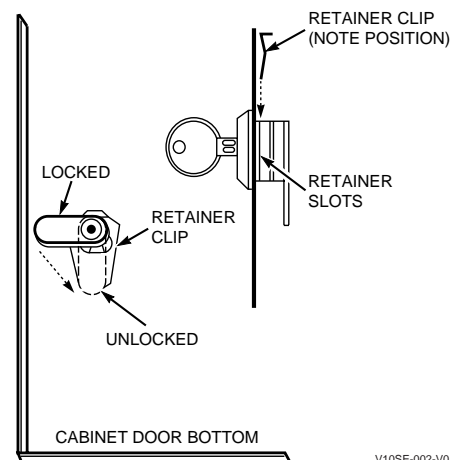

Figure 1. Installing the Lock



Before installing the cabinet's contents, remove the metal cabinet knockouts required for wiring entry. Do not attempt to remove the knockouts after the circuit board has been installed.

Mounting the Control's Circuit Board Alone in the Cabinet

To mount the circuit board alone in the cabinet, follow these steps:

1. Hang two mounting clips* (provided) on the raised cabinet tabs (see Detail B in *Figure 2* below).
2. Insert the top of the circuit board **between** the rows of slots at the top of the cabinet as shown in Detail A.
3. Position the base of the board onto the mounting clips and secure both to the cabinet with the supplied screws (see Detail B).

* These mounting clips are also used for mounting the same end of the circuit board when an RF receiver is mounted above it, as in *Figure 3*.

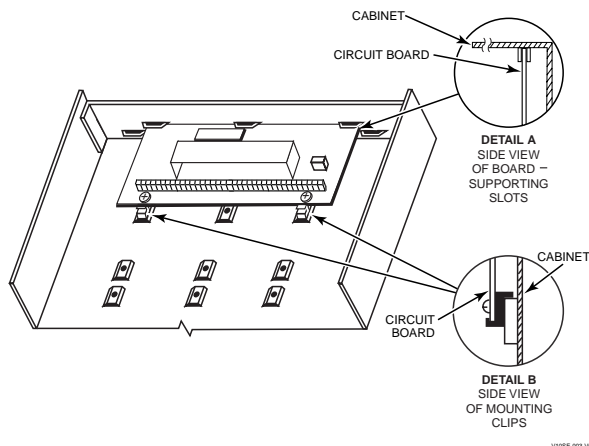

Figure 2. Mounting the Control's Circuit Board Alone in the Cabinet

Mounting the Control and RF Receiver Circuit Board in the Cabinet

To mount the control and RF receiver boards together in the cabinet, do the following:

1. Hang two mounting clips (provided with receiver) on the raised cabinet tabs, as shown in Detail B in *Figure 3*.
2. Insert the top of the receiver board (removed from its own case as described in *its* instructions) between the rows of slots at the top of the cabinet, as shown in Detail A.
3. Position the base of the receiver board onto the mounting clips and secure both to the cabinet with the supplied screws (see Detail B).
4. Hang two mounting clips (supplied with the control board), on the raised cabinet tabs as shown in Detail C in *Figure 3*.
5. Insert the top of the control board into the slots of the mounting clips secured in step 3 above.
6. Position the lower end of the control board into place on the mounting clips and secure both to the cabinet with the two supplied screws.
7. Insert both grounding lugs (supplied with the receiver) through the top of the cabinet into the *left-hand* terminals of the antenna blocks (located at the upper edge of the receiver board), and secure them to the cabinet with the screws provided, as shown in Detail D.
8. Insert the receiver's antennas through the top of the cabinet, into the blocks' *right-hand* terminals, and tighten the screws.

Refer to setup and wiring instructions for the receiver in the *WIRELESS EXPANSION (5800 RF SYSTEMS)* section.

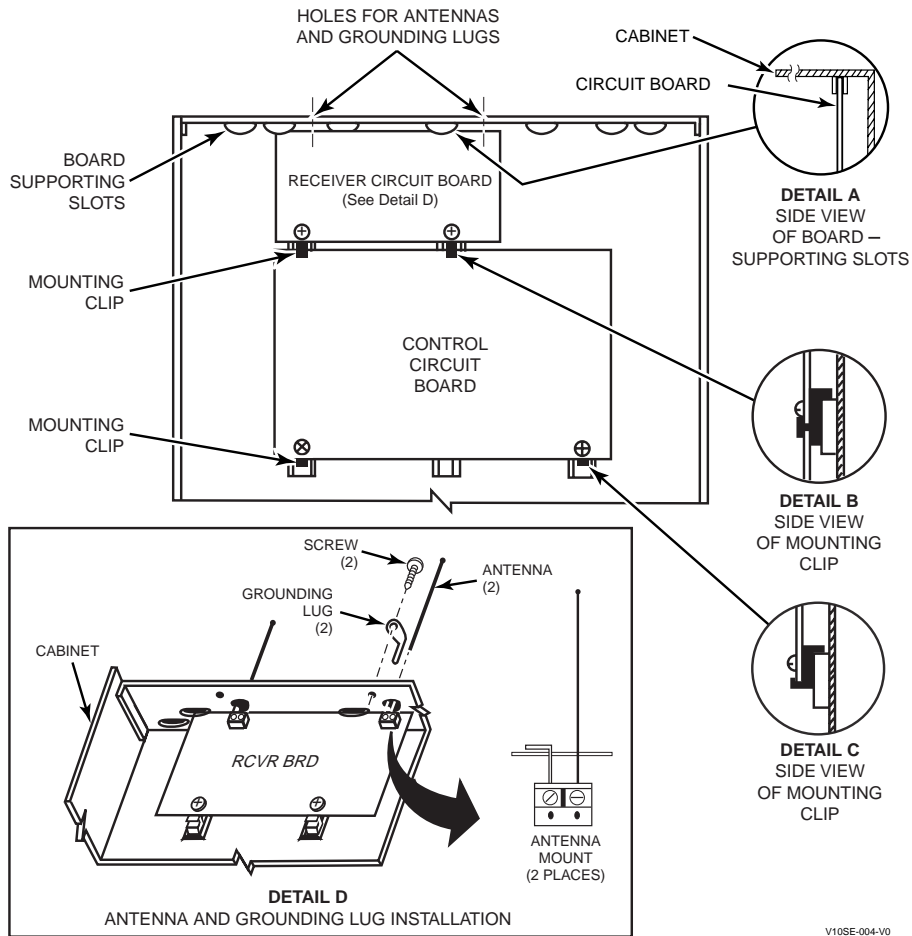

Figure 3. Mounting the PC Board and RF Receiver Together in the Cabinet

Standard Phone Line Connections



The wiring connections shown here are not applicable if a 4285/4286 VIP Module is used. Refer to the 4285/4286 VIP MODULE section for information regarding phone line connections, which are different than those shown here.

Connect incoming phone line and handset wiring to the main terminal block via an RJ31X jack (CA38A jack in Canada) as follows and as shown in *Figure 4*.

- Term. 17: Local Handset (TIP – Brown*).
- Term. 18: Local Handset (RING – Gray*).
- Term. 19: Incoming Phone Line (TIP – Green*).
- Term. 20: Incoming Phone Line (RING – Red*).

* Colors of wires in Direct Connect Cord.

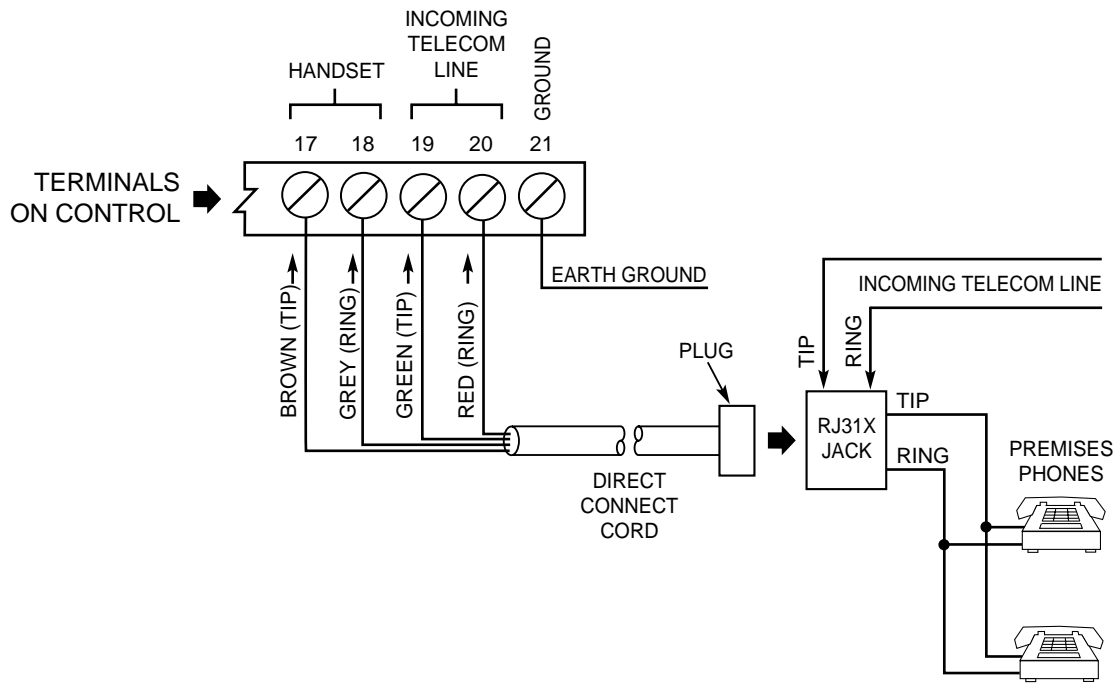

V10SE-024-V0

Figure 4. Standard Telephone Line Connections

Remote Keypads

In This Section

- ◆ *Keypads That May Be Used*
- ◆ *Wiring to the Keypads*
- ◆ *Mounting the Keypads*
- ◆ *Supplementary Power for Additional Keypads*
- ◆ *Preliminary Checkout Procedure*

This section lists the wired keypads that may be used and provides instructions for wiring and mounting the keypads.

A preliminary checkout procedure is also provided to ensure that the connected keypads are functioning properly in the system.

Keypads That May Be Used

- Fixed-Word Display: 6127, 6128, 6137
- Alpha Display: 6138, 6139
- Up to 4 keypads, independent of auxiliary power considerations (you may need to use an auxiliary power supply if the 500mA aux. output is exceeded)



If you are going to use a 4285/4286 VIP Module, you **MUST** use addressable keypads (6128, 6137, 6138, 6139) in the system, but set to the non-addressable mode (address 31).

Wiring to the Keypads

1. Determine wire gauge by referring to the wiring length/gauge chart below.

For devices (keypads, RF receivers, etc.) connected to a single 4-wire run, determine the current drawn by all units connected to the single wire run, then refer to the Wiring Run chart to determine the maximum wire length that can be safely used for each wire size. Current draw for all devices can be found in the *SPECIFICATIONS & ACCESSORIES* section.

NOTE: Refer to “Auxiliary Device Current Draw Worksheet” in the *FINAL POWER-UP* section for current draw for all keypads.



Maximum wire lengths for any device that is homerun to the control can also be determined from the chart, based on the current draw of that device **alone**.

Wiring Run Chart for Devices* Drawing Aux Power From the Control (12V+ & 12V-)

Wire Size	TOTAL CURRENT DRAWN BY ALL DEVICES CONNECTED TO A SINGLE WIRE RUN			
	50mA or less	100mA	300mA	500mA
#22	500 ft (152m)	250 ft (76m)	80 ft (24m)	50 ft (15m)
#20	750 ft (228.6m)	380 ft (116m)	130 ft (39.6m)	80 ft (24m)
#18	1300 ft (396m)	650 ft (198m)	220 ft (67m)	130 ft (39.6m)
#16	1500 ft (457m)	1000 ft (305m)	330 ft (100.5m)	200 ft (70m)

* Includes keypads, RF receivers, relay units, and 4285/4286 VIP Modules.



The length of all wire runs must not exceed 1500 feet (457m) when unshielded quad conductor cable is used (750 feet if shielded cable is used). This restriction is due to the capacitive effect on the data lines when quad cable is used.

- Run field wiring from the control to the keypads (using standard 4-conductor twisted wire cable using the wire gauge determined in step 1).
- Connect remote keypads to terminals 4, 5, 6, and 7 on the control board, as shown in Figure 5.

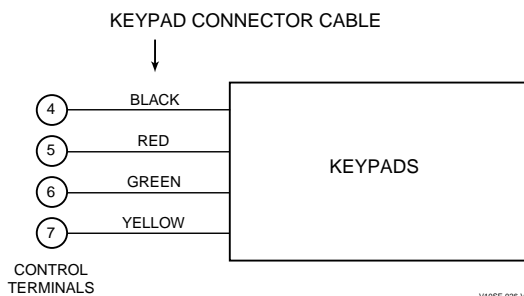

Figure 5. Keypad Connections to the Control Board

Mounting the Keypads

- Make sure addressable-type keypads** (6128, 6137, 6138, and 6139) are set to non-addressable mode (address 31), which is the factory default setting. Refer to the instructions provided with the keypad for address setting procedure.
- Mount the keypads** at a height that is convenient for the user. Refer to the instructions provided with the keypad for mounting procedure.

You can either surface mount or flush mount keypads (using an appropriate Trim Ring Kit: 6139TRK). Refer to the mounting instructions and template included with the keypad and/or trim ring kit for specific information.

Supplementary Power for Additional Keypads

The control provides 500mA for powering keypads (up to a maximum of 4) and other devices from the auxiliary power output. The backup battery will supply power to these keypads in the event that AC power is lost.

When the control's auxiliary power load for all devices exceeds 500mA, you can power additional keypads from a regulated, 12VDC power supply (e.g., 487-12 supplies 12V, 250mA; 488-12 supplies 12V, 500mA). Use a UL Listed, battery-backed supply for UL installations.

The 487-12/488-12 power supplies have a backup battery that can power these keypads in the event of AC power loss.



Keypads powered from supplies that do not have a backup battery **will not function** when AC power is lost. Therefore, be sure to power at least one keypad from the Control's auxiliary power output.



Connect the additional keypads as shown in *Figure 6*, using the keypad wire colors shown. Be sure to observe the current ratings for the power supply used.

Make connections directly to the screw terminals as shown in *Figure 6*. Make no connection to the keypad blue wire (if present).

Be sure to connect the negative (-) terminal on the Power Supply unit to terminal 4 (AUX -) on the control.

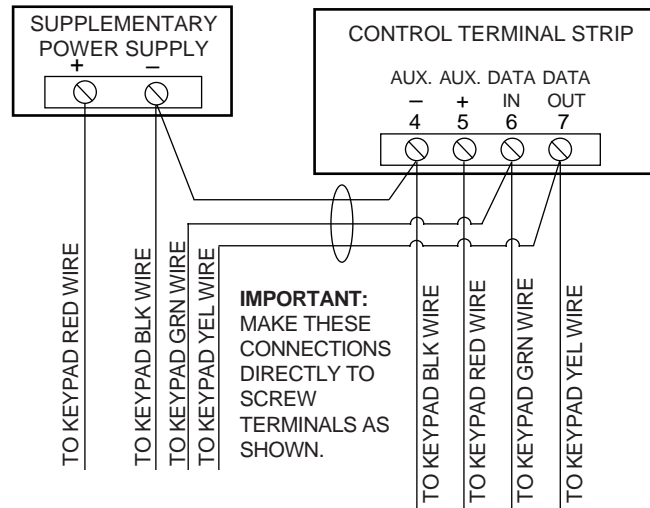

V10SE-008-V0

Figure 6. Using a Supplementary Power Supply for Keypads

Preliminary Checkout Procedure

If you want to check that the system is working before connecting field wiring from zones and devices, do the following:

1. Temporarily connect a 1000 ohm end-of-line resistor across each of the basic hardwire zones 1–6, as shown in the Summary of Connections diagram.

Without actual zone wiring or EOL resistors connected, the keypads in the system will not display the “Ready” message.

2. Power-up the system temporarily by plugging the AC transformer (previously wired to the control) into a 120VAC outlet.

3. **Busy – Standby** (on alpha keypads) or **dI** (on fixed-word keypads) will be displayed.

After approximately 1 minute*, the green READY LED (or POWER LED on some types of keypads) should light, and the word "READY" (on fixed-word keypads) or the words "DISARMED...READY TO ARM" (on alpha keypads) should be displayed, indicating the system is functioning properly.

* To bypass the 1-minute delay, press # + 0.

If the “Ready” message is not displayed on any of the keypads in the system, or a “Not Ready” message is displayed, check the keypad wiring connections, and make sure each of the 6 basic hardwired zones has a 1000 ohm resistor connected across its terminals.

Do not remove the EOL resistors until you are ready to make connections to the hardwired zones, to allow for testing later in the manual.



If an OC or OPEN CIRCUIT display is present on the keypad, data from the control is not reaching the keypad. Check the wiring.

Basic Hardwired Zones 1–6

In This Section

- ◆ *Installing the Hardwired Zones*
- ◆ *Programming Hardwired Zones*

Installing the Hardwired Zones

Common Characteristics for Zones 1–6

- Response time from 300 - 500 milliseconds (400 milliseconds nominal).
- Zone 3 can be programmed (in field ✕52) for normally-closed sensor fast response (10mSec max) to an open (suitable for vibration type contacts). Default response is 400mSec nominal, which should be used for most standard contacts.
- EOLR supervised zones support both open-circuit and closed-circuit devices.
- As many 4-wire smoke detectors as can be powered from Aux Power on the control (on zone 5).

UL

4-Wire Smoke/Combustion detectors are **not** permitted in UL installations.

Wiring Burglary and Panic Devices to Zones 1–6

To wire burglary and panic devices to zones 1-6, perform the following steps, referring to *Figure 17. VISTA-10SE Summary of Connections* on the inside back cover of this manual.

1. Connect sensors/contacts to the hardwired zone terminals (8 through 16). See the Summary of Connections diagram.
2. Connect closed circuit devices in series in the high (+) side of the loop. The EOL resistor must be connected in series with the devices, following the last device. See the Summary of Connections diagram.
3. Connect open circuit devices in parallel across the loop. The 1000 ohm EOLR must be connected across the loop wires *at the last device*.



If the EOLR is not at the end of the loop, the zone will not be properly supervised, and the system may not respond to an open circuit on the zone.

Wiring 4-Wire Smoke/Combustion Detectors on Zone 5

The system will support as many 4-wire detectors as can be powered from Auxiliary Power on the control on zone 5. Refer to the detector's instructions for complete details regarding its proper installation and operation.

1. Connect 12-volt power for the detectors from Auxiliary Power terminals **4** and **5** (which will interrupt power for fire alarm reset). Observe proper polarity when connecting detectors. See *Figure 7*.
2. Connect detectors (including heat detectors, if used) across terminals of zone 5. All detectors must be wired in parallel.



Remove 1000 ohm EOL resistor if connected across the zone terminals. You must connect the EOL resistor across the loop wires at the last detector.

- To meet NFPA 72 requirements, you must use a supervisory module to supervise power (e.g., System Sensor No. A77-716B Relay module).

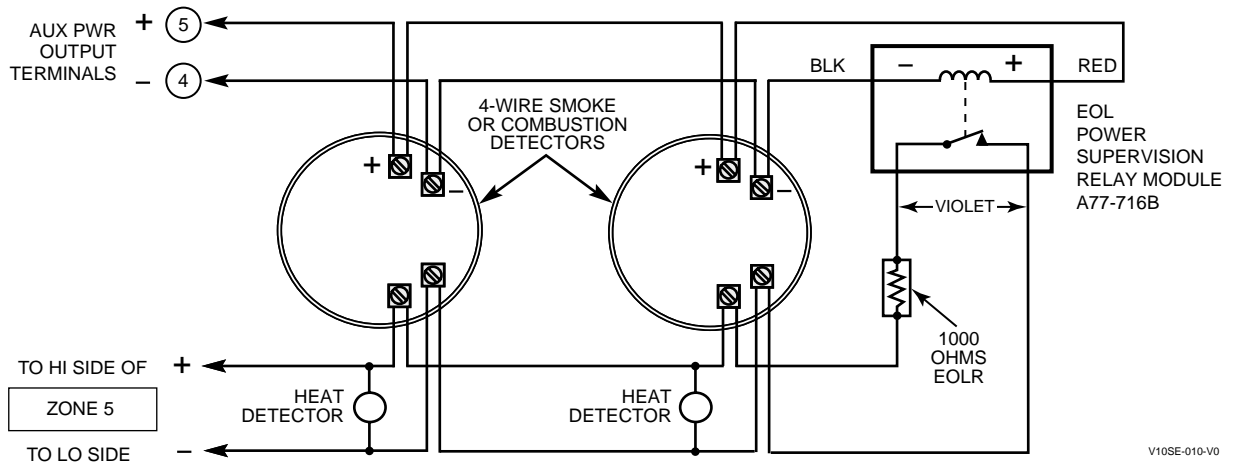

Figure 7. 4-wire Smoke Detector Connections (Zone 5)

Compatible System Sensor 4-Wire Smoke/Combustion Detectors

1412	4-wire ionization products of combustion detector
2412	4-wire photoelectric smoke detector
2412TH	4-wire photoelectric smoke detector w/135°F (57°C) heat detector
A77-716B	EOL relay module (supervisory module for wired 4-wire fire zone)
2112/24T	Low-profile 4-wire photoelectric smoke detector w/135°F (57°C) heat detector

Programming Hardwired Zones

Each zone must be programmed into the system using the *56 Zone Programming Mode or *58 Expert Programming Mode, which assigns characteristics that define the way the system responds to faults on that zone. Refer to the *ZONE RESPONSE TYPE DEFINITIONS* and *ZONE PROGRAMMING* sections for specific instructions on programming hardwired zones.

Wireless Expansion (5800 System)

In This Section

- ◆ *About Wireless Expansion*
- ◆ *About Jam Detection and Reporting*
- ◆ *Installing the 5881/5882 Receiver*
- ◆ *5800 Series Transmitters*
- ◆ *Installing the 5800TM Module*
- ◆ *Installing 5800 Series Transmitters*

About Wireless Expansion

The VISTA-10SE supports up to 16 wireless zones that may be used exclusively or in addition to hardwired zones 1 through 6.

The receiver detects signals from wireless transmitters within a nominal range of 200 feet.

The following 5881 Receivers may be used with this system (5882 in Canada), and each supports the number of zones shown:

RF Receiver	No. of Zones
5881L/5882L	up to 8
5881M/5882M	up to 16
5881H/5882H	up to 16

UL

Wireless may not be used in UL Commercial Burglary installations.



In Canada, 5800 systems must use 5882 Series receivers. Information relative to the 5881 Series of receivers applies as well to the 5882 Series. 5881 and 5882 Series receivers can support the same 5800 type transmitters.



Any zone *number* from 10–25 can be used as a 5800 Series wireless zone (do not confuse this with the number of zones that can be used, which is shown in table above).

Receiver Supervision

The receiver is supervised. The following conditions cause a Trouble report to be generated and **CHECK** and **ZONE 09** messages to be displayed:

- Communication between the panel and the receiver is interrupted.
- or**
- No valid RF signals from at least one supervised wireless transmitter are received within 12 hours.

House Identification

If you are using a 5804BD, 5827, or 5827BD Wireless Keypad with the system, you must program a House ID Code (01-31) in field *24 to establish proper communication. The keypad must be set to the same ID.

House ID 00 disables all wireless keypads.

Installing the 5881/5882 Receiver

RF System Installation Advisories

Follow the guidelines below when installing the RF receiver. (Disregard if the receiver is mounted in the control cabinet.)

- Place the RF receiver in a high, centrally located area for best reception.
- Do not locate the receiver or transmitters on or near metal objects. This decreases range and/or block transmissions.
- Do not locate the receiver in an area of high RF interference (revealed by frequent or prolonged lighting of the LED in the receiver; random flicker is OK).
- The RF receiver must be at least 10 feet from any remote keypads to avoid interference from the microprocessors in those units.

Installation and Setup of the 5881/5882 Receiver

To install the receiver, take the following steps (refer to *Figure 8* below):

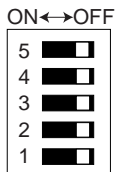

1. Set the receiver's DIP switch for device address 0, as described in its instructions (all switches shown at left are in the OFF position).
2. Mount the receiver. The RF receiver can detect signals from transmitters within a nominal range of 200 feet. Take this into consideration when determining mounting location.
3. Connect the receiver's wire harness to the control's keypad terminals (4, 5, 6, and 7). Plug the connector at the other end of the harness into the receiver.
4. Refer to the installation instructions provided with the receiver for further installation procedures regarding antenna mounting, etc.

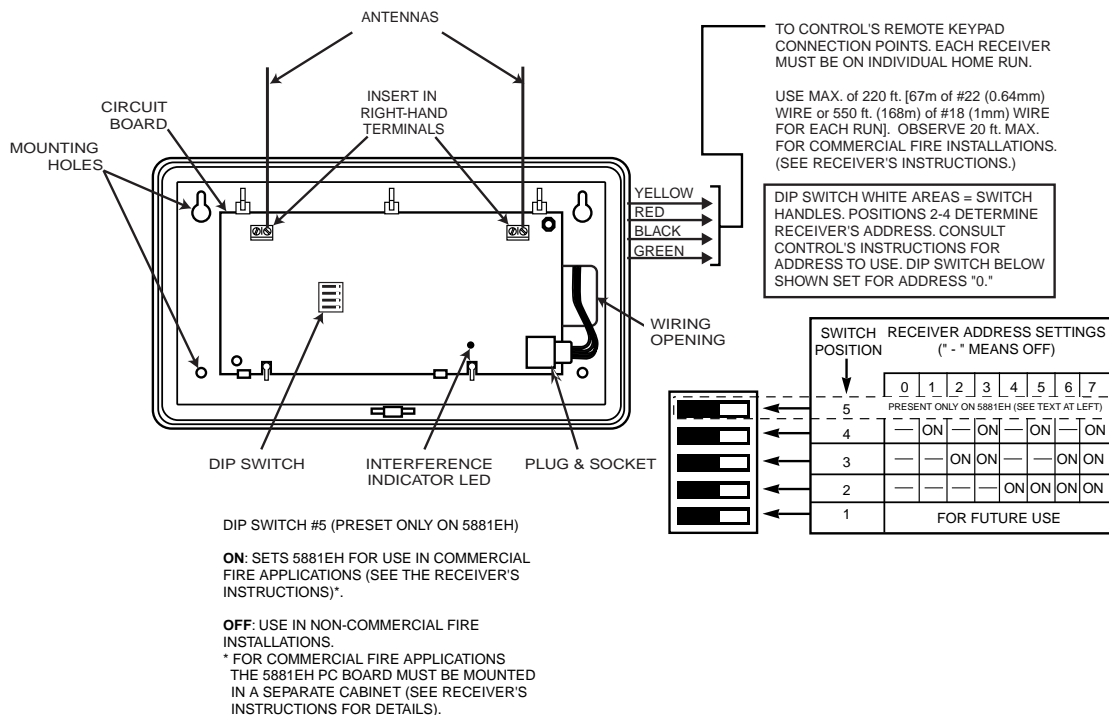

Figure 8. 5881/5882 RF Receiver (cover removed)

Installing the 5800TM Module

Installation of this module is necessary only if you are using one or more 5827BD Wireless Bi-directional keypads, 5804 or 5804BD Transmitters (wireless keys).

Mounting the 5800TM Module

The 5800TM must be located next to the RF receiver (between one and two feet from the receiver's antennas). The 5800TM must **not** be installed within the control cabinet. Mount the unit using its accompanying mounting bracket.

Wiring the 5800TM Module

Connect the 5800TM to the control panel's keypad connection terminals, using the supplied connector with flying leads, as follows:

Wire	Terminal on Control
BLACK (Ground)	Terminal 4
RED (+12VDC)	Terminal 5
GREEN (Data to Control)	Terminal 6
YELLOW (Data from Control)	Terminal 7
BLUE	Not Used

Do not cut any of the jumpers on the 5800TM when using it with the VISTA-10SE.

For additional information, refer to the 5800TM's instructions.

About Jam Detection and Reporting

When field *22, option 4 (RF SYSTEM) is selected, a 5800 Series receiver detecting a jam condition sends an **E344** (RF Receiver Jam Detect) Contact ID report to the central station. At the same time, a **Rcvr Jam** (on alpha keypads) or **CHECK 90** (on fixed-word keypads) message alternates with the present system message on the keypad. When the jam condition is cleared, a **Restore** message is sent to the CS. Entering a code and OFF restores the keypad display.

The default for this option is 0 (disabled).



Normal use of a 5827 wireless keypad may cause a false RF jam message to be displayed in systems that have been programmed for RF Jam Detection.

5800 Series Transmitters

Programming Wireless Zones

5800 Series transmitters have built-in serial numbers that must be enrolled into the system using the *56 or *58 programming modes in the *ZONE PROGRAMMING* section, or input to the control via the downloader. 5800 Series transmitters (except 5827, described separately) do not have DIP switches.

Program each transmitter's zone number into the system using *56 or *58 mode (refer to the *Zone Programming* section). Some transmitters, such as the 5816 and 5817, can support more than one "zone" (referred to as loops or inputs). On the 5816, for example, the wire connection terminal block is loop 1, the reed contact is loop 2. Each loop must be assigned a different zone number.



The 5816 and 5817 transmitters do not have EOL supervision of their loop wiring. Therefore, for UL Household Burglary installations, the loop wiring may not exceed 3 feet.

For button transmitters (RF keys), such as the 5801, 5804, and 5804BD, you must assign a unique zone number to each individual button used on the transmitter. Each button on the transmitter also has a pre-designated loop or input number, which is automatically displayed on the keypad.

Programming an RF House ID

Programming an RF House ID (01–31) in field *24 is necessary **only** if you are using 5827 or 5827BD Wireless Keypads or 5804BD Transmitters. An RF House ID is not necessary for other 5800 Series Transmitters, and the entry should be left at 00 (default) in those cases.

The 5827 reports low-battery status as zone 00.

Transmitter Supervision

Except for some transmitters that may be carried off-premises (5802, 5802CP, 5803, 5804, 5804BD, 5827, and 5827BD), each transmitter is supervised by a check-in signal that is sent to the receiver at 70-90 minute intervals. If at least one check-in is not received from each supervised transmitter within a 12-hour period, the “missing” transmitter number(s) and the message **CHECK** is displayed.



In accordance with ULC standards, the RF supervision period for the VISTA-10SE is three hours for fire zones (Zone Type 9) and 12 hours for all other zone types.

The supervision for a particular transmitter in the system that may also be carried off the premises (5801, 5802MN) may be turned off by enrolling it as a “UR” (unsupervised RF) type, as described later.

5800 Series transmitters have built-in tamper protection and annunciate as a Check condition if covers are removed.

Transmitter Input Types

All of the transmitters described have one or more unique, factory-assigned input (loop) ID codes. Each of the inputs requires its own programming zone (for example: a 5804's four inputs require four programming zones). Refer to the *ZONE PROGRAMMING* section.

Transmitters can be enrolled as one of the following types:

Type	Description
RF (Supervised RF)	Sends periodic check-in signals, as well as fault, restore, and low-battery signals. The transmitter must remain within the receiver's range.
UR (Unsupervised RF)	Sends all the signals that the “RF” type does, but the control does not supervise the check-in signals. The transmitter may therefore be carried off-premises.
BR (Unsupervised Button RF)	Sends only fault signals. It will not send a low-battery signal until it is activated. The transmitter may be carried off-premises.

Transmitter Battery Life



Do not install batteries in wireless transmitters until you are ready to enroll the transmitters during system programming. After enrolling, batteries need not be removed.

Batteries in the wireless transmitters may last from 4 to 7 years, depending on the environment, usage, and the specific wireless device being used. Factors such as humidity, extreme temperatures, as well as large temperature variations may all reduce the actual battery life in a given installation.

The wireless system can identify a true low-battery situation, thus allowing the dealer or user of the system time to arrange a change of battery and maintain protection for that point within the system.

Some transmitters (e.g., 5802, 5802CP, and 5804) contain long-life but nonreplaceable batteries, and no battery installation is required. At the end of their life, the complete unit must be replaced (and a new serial number enrolled by the control).

Button-type transmitters (such as 5801, 5802, 5802MN/MN2, 5802CP, and 5804) should be periodically tested for battery life.

The 5802MN and 5804 Button Transmitters have replaceable batteries.

Using the Transmitter Sniffer Mode

The Transmitter Sniffer mode is a procedure that verifies that all transmitters have been properly programmed. To verify programming, refer to the *TESTING THE SYSTEM* section.

5800 Series Transmitters Table

Model	Description	Input Type and Special Notes
5801	Wireless Panic Transmitter	Enroll as "3" for RF (supervised), or "4" for UR (unsupervised). Unit has 4 pushbuttons, each with a unique input (loop) code. Each pushbutton must be assigned to a zone. NOTE: Input loop (button) No. 4 must always be used.
5802 5802CP	Pendant Belt Clip (Personal Emergency) Transmitters	Enroll as "5" for BR (button-type transmitter).
5802MN 5802MN2	Miniature Personal Emergency Trans.	Enroll as "3" for RF (supervised), or "4" for UR (unsupervised). Single pushbutton-type transmitter.
5804 5804BD	Wireless Key Transmitter	Enroll as "5" for BR (button-type transmitter). Has 4 pushbuttons, each with a unique input (loop) code. Each pushbutton must be assigned to a zone. NOTE: All buttons must be assigned the same input type.
5806 5807 5808 5807L 5807LT 5807LST 5808LST	Wireless Photoelectric Smoke Detectors Low-profile version of the Wireless Photoelectric Smoke Detectors	Enroll as "3" for RF (supervised). At the "INPUT S/N" prompt, fault the detector as follows: 1. On many detectors, you must press a special test switch (not test button) to fault the detector (see detector's instructions). NOTE: With some detectors, you must short two contacts to fault the detector. Disengage the detector's cover and swing it open. These contacts are on the PC board near a blue jumper (see detector's instructions). Momentarily short these contacts with a small screwdriver. Two keypad beeps occur when the detector is faulted the first time. 2. Wait 6 to 8 seconds, then press and release the test switch (or momentarily short the contacts) again. If the control has accepted the input code, 3 beeps sound and the enrolled input (loop) number is displayed.
5809	HeatSensor, 135° Detector/Transmitter	
5816 5816MN	Door/Window Transmitter	Enroll as "3" for RF (supervised). Has two unique input (loop) zones: one for a wired closed-circuit contact loop, and the other for a built-in reed switch (used in conjunction with a magnet).
5816TEMP	Low Temp Sensor	Either or both may be used.
5817	Multi-Point Universal Transmitter	Enroll as "3" for RF (supervised). Has three unique input (loop) codes: one for a DIP switch-set "Primary" contact loop, and the others for two "Auxiliary" closed-circuit contact loops. The "Primary" loop may be set for: <ul style="list-style-type: none"> • Repeating or Single Transmission • Normally Open or Normally Closed circuit • Slow or Fast Response 3-Minute or no Transmission Inhibit

5800 Series Transmitters Table (continued)

Model	Description	Input Type and Special Notes
5817 (cont'd.)	Multi-Point Universal Transmitter (cont'd.)	DIP Switches: Set all DIP switches to the OFF position when enrolling the serial number. NOTE: All loops must be assigned the same input type.
5818	Recessed Magnetic Contact Transmitter	Enroll as "3" for RF (supervised).
5819 5819BRS 5819WHS	Shock Processor Transmitter	Enroll as "3" for RF (supervised). Has three unique input (loop) zones: one for a wired closed-circuit contact loop, one for use with inertia-type shock detectors (mounted externally), and one for a built-in reed switch (used in conjunction with a magnet).
5849 5850 5852	Glassbreak Detector/Transmitter	Enroll as "3" for RF (supervised).
5890 5890P1	PIR Detector/Transmitter	Enroll as "3" for RF (supervised). The cover must be on the unit when enrolling the serial number.



When "enrolling" a transmitter's ID code(s), any PIR in the vicinity that is not being enrolled should be covered with a cloth, tissue, etc. to prevent activation.

Installing 5800 Series Transmitters

To be sure reception of the transmitter's signal at the proposed mounting location is adequate, perform a Go/No Go Test in the *TESTING the SYSTEM* section.

Setting DIP Switches on the 5827 Transmitter(s)

You must set a 5827 Transmitter to the programmed House ID, using its DIP switches.

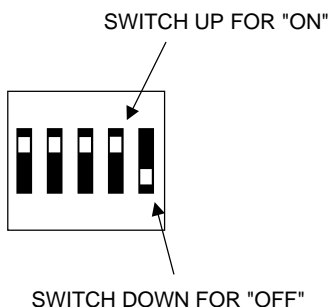

SHOWN SET FOR HOUSE ID # 30

	DIP SWITCH POSITION				
	1	2	3	4	5
1	-	-	-	-	UP
2	-	-	-	UP	-
3	-	-	-	UP	UP
4	-	-	UP	-	-
5	-	-	UP	-	UP
6	-	-	UP	UP	-
7	-	-	UP	UP	UP
8	-	UP	-	-	-
9	-	UP	-	-	UP
10	-	UP	-	UP	-
11	-	UP	-	UP	UP
12	-	UP	UP	-	-
13	-	UP	UP	-	UP
14	-	UP	UP	UP	-
15	-	UP	UP	UP	UP
16	UP	-	-	-	-

HOUSE ID	DIP SWITCH POSITION				
	1	2	3	4	5
17	UP	-	-	-	UP
18	UP	-	-	UP	-
19	UP	-	-	UP	UP
20	UP	-	UP	-	-
21	UP	-	UP	-	UP
22	UP	-	UP	UP	-
23	UP	-	UP	UP	UP
24	UP	UP	-	-	-
25	UP	UP	-	-	UP
26	UP	UP	-	UP	-
27	UP	UP	-	UP	UP
28	UP	UP	UP	-	-
29	UP	UP	UP	-	UP
30	UP	UP	UP	UP	-
31	UP	UP	UP	UP	UP

Relay Output Devices

In This Section

◆ *Relay Device Basics*

◆ *Programming Options*

◆ *4204 Relay Modules*

Relay Device Basics

Relays are programmable switches that can be used to perform many different functions. They can be used to turn lights on and off, control sounders, or for status indications. In this system, each relay must be programmed as to how to act (ACTION), when to activate (START), and when to deactivate (STOP). Each of these is described below.

The control supports a total of 4 output relays.



The 4204 Relay modules provide Form C (normally open and normally closed) contacts.

In *80 and *81 interactive modes, a series of keypad prompts will request entries for programming of the Relay outputs used in the system. Refer also to "OUTPUT RELAY DEVICE WORKSHEET FOR *80 AND *81 INTERACTIVE MODES" in the blank programming form provided in the separate **Programming Form** manual.

4204 Relay Modules

4204 Relay Unit (if installed in cabinet)

1. Insert self-tapping screws (provided) in two adjacent raised cabinet tabs. Leave the heads projecting 1/8".
2. Hang the unit on the screw heads via two of the slotted holes at the rear of its housing, as shown in *Figure 9* below.
3. The 4204's cover can be left off if the unit's DIP switch is set with its position 1 "ON" (to the right) as shown in its instructions. The tamper-protected cover is necessary for installations outside of the control's cabinet.

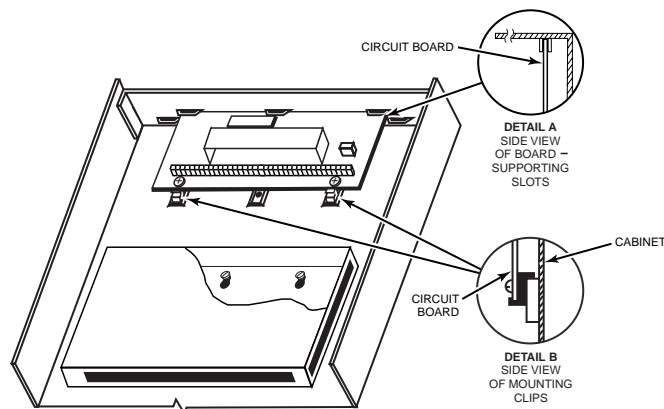

V105E-003-V0

Figure 9. Mounting the PC Board in the Cabinet with a 4204 Relay Unit

4204 Setup

The 4204 unit can be mounted either remotely or in the control panel. The following steps should be taken to properly set up the 4204:

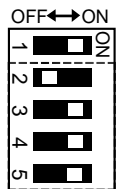

1. **Connect the 4204 to the control's remote keypad terminals (4–7)**, using the connector supplied with the 4204. Use standard 4-conductor twisted cable for long wiring runs.
2. **Set the 4204's DIP switch for a device address of "1"** (switch 2 "OFF" and switches 3, 4, and 5 "ON"). Switch 1 determines the unit's cover tamper response ("ON" = disabled, "OFF" = enabled).
3. **Connect the desired field wiring** to the unit's relay contact terminals. See *Figure 10* below.

Supervision

4204 modules are supervised against removal. **CHECK** and zone **09** will be displayed if a module is disconnected from the control's keypad terminals (4, 5, 6, and 7).

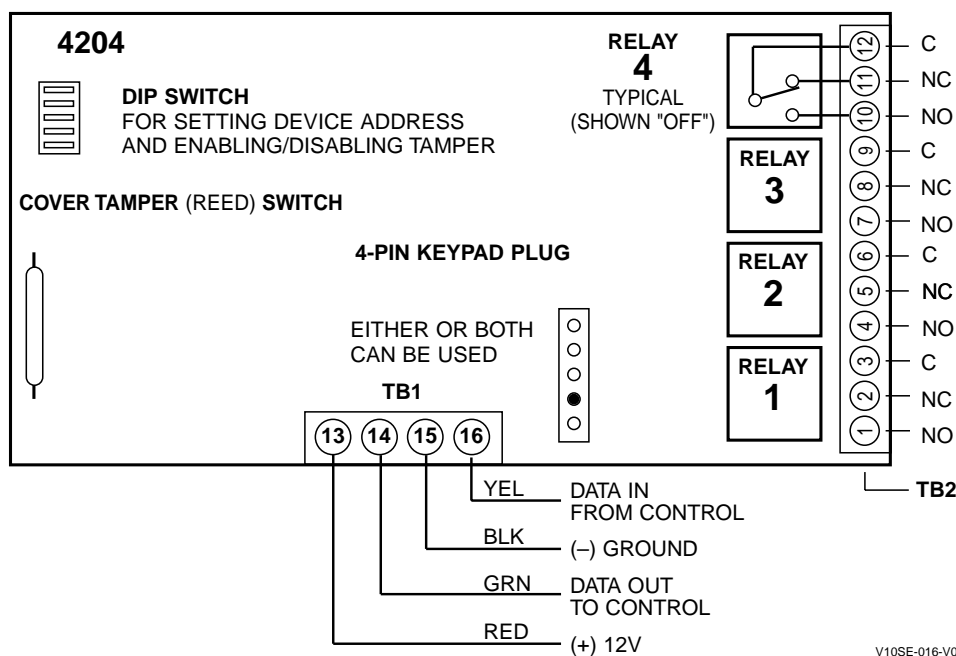

Figure 10. 4204 Connections to Control

Programming Options

In the VISTA-10SE, each device must be programmed as to how to act (ACTION), when to activate (START), and when to de-activate (STOP). Refer to the programming procedures for *80 and *81 interactive modes that are provided in the *MECHANICS of PROGRAMMING*, *OUTPUT DEVICE PROGRAMMING*, and *ZONE LISTS* sections for specific programming details.

4285 and 4286 VIP Module

In This Section

◆ *Installing the VIP Module*

◆ *Checking 4285/4286 VIP Module Operation*

◆ *Programming the 4285/4286 VIP Module*

Installing the (Voice Interactive Phone) Module

General Information

The 4285/4286 VIP Module is an add-on accessory for the VISTA-10SE that permits access to the security system via a TouchTone phone (either on premises or by a call-in when away).

The VIP Module can announce many of the same words that would normally be displayed on an alpha keypad under the same system conditions.



When using the VIP Module, addressable keypads must be used in the system, but set to the non-addressable mode (address 31); i.e., do not use a 6127 keypad.

When properly connected, the VIP Module will enable the user to do the following via a TouchTone telephone:

- Receive synthesized voice messages over the phone regarding the status of the security system.
- Arm and disarm the security system and perform most other commands using the telephone keypad, with voice annunciation provided over the phone as confirmation after a command is entered.

The phone used for phone access must have TouchTone capability, though TouchTone service is not necessary (if premises uses PULSE dialing, switchable phones must be set for TouchTone temporarily before attempting phone access).

A ***Phone Access User's Guide*** for phone access to the security system is provided with the VIP Module for the user of the system.

UL

The VIP Module is not Listed for UL installation use.

Mounting the VIP Module

The VIP Module may be mounted in the control cabinet if space is available or, if this is not possible, on the side of the cabinet or adjacent to it.

When mounting the VIP Module outside the cabinet, use the screw holes at its rear. That will permit it to be mounted horizontally or vertically (double-sided tape may be used, if preferred). Wires can be brought out from the side or back (a round breakout is also available on the back).

Affix the VIP Module's connections label (supplied separately) to the inside of the VIP Module's cover if the cover is used. If you have installed the module within the cabinet, affix the label to the inside of the control cabinet's door.

VIP Module Wiring

The VIP Module is wired between the control panel and the premises handset(s). It listens for touch-tones on the phone line and reports them to the control panel. During on-premises phone access, it powers the premises phones; during off-premises phone access, it seizes the line from the premises phones and any answering machines.

NOTE: The phone lines must be in service for the VIP Module to function, even when accessing the system from an on-premises phone.

1. Make 12V (+) and (-) and data in and data out connections from the VIP Module to the control, using the connector cable supplied with the VIP Module (see *Figure 10*).

Color Lead	Terminal On Control *
GREEN	DATA IN (terminal 6)
BLACK	AUX - (terminal 4)
RED	AUX + (terminal 5)
YELLOW	DATA OUT (terminal 7)

* These are the same connections as those used for remote keypads.

2. Insert the keyed connector at the other end of the connector cable into the mating header on the VIP Module (see diagram on next page for location of the header).
3. Connect terminals 1 through 4 on the VIP Module as shown in the Wiring Table and in the 4285/4286 wiring diagram that follows.



Use an RJ31X jack with a direct-connect cord and make all connections exactly as shown. If the leads on the direct-connect cord are too short to reach their assigned terminals, splice additional wires to them, as required.

4285/4286 WIRING TABLE

4285/4286/4286 Terminal	Connects to:
1. Phone In (Tip)	Terminal (17) on control.
2. Phone In (Ring)	Terminal (18) on control.
3. Phone Out (Tip)	BROWN lead from direct-connect cord.
4. Phone Out (Ring)	GRAY lead from direct-connect cord.
5. NOT USED	—
6. Output High	Not used (4285). Spkr High on 4286.
7. Output Rtn	Not used (4285). Spkr Return on 4286.



If no touch-tones are produced following access to the security system **from on-premises** (this problem may arise in rare cases), it may be necessary to reverse the wires connected to terminals 3 and 4 on the VIP Module **and** the wires connected to terminals (17) and (18) on the control. *Figure 11* shows the wiring connections that will provide proper operation in most cases.

Caller ID Units

If the telephone system on the premises includes a Caller ID unit, connect the ID unit directly to the “Handset” terminals (17 and 18) on the control, as shown in *Figure 11*.

4285/4286 VIP Module WIRING NOTES:

1. Wire the VIP Module exactly as shown, using a direct-connect cord and RJ31X jack.
2. If you do not hear tones when pressing keys after accessing the security system via an on-premises phone, try reversing the pair of wires connected to terminals 3 and 4 on the VIP Module **and** the pair of wires connected to terminals 17 and 18 on the control.
3. If you hear an error signal (fast busy signal) when trying to access the system via the phone, check for correct line seizure wiring, as described in note 4.
4. Connection to the incoming telco line via a RJ31X jack and direct-connect cord, as shown in this diagram, is essential, even if the system is not connected to a central station. **The 4285 or 4286 will not function if this is not done.**

The house phone lines (gray and brown wires) must be wired to the VIP Module terminals, not to the control terminals. Otherwise, an error signal (fast busy signal) will occur when you try to access the system from an on-premises phone.

5. If the telephone system on the premises includes a Caller ID unit, connect the unit **directly** to the "Handset" terminals (17 and 18) on the control, as shown.

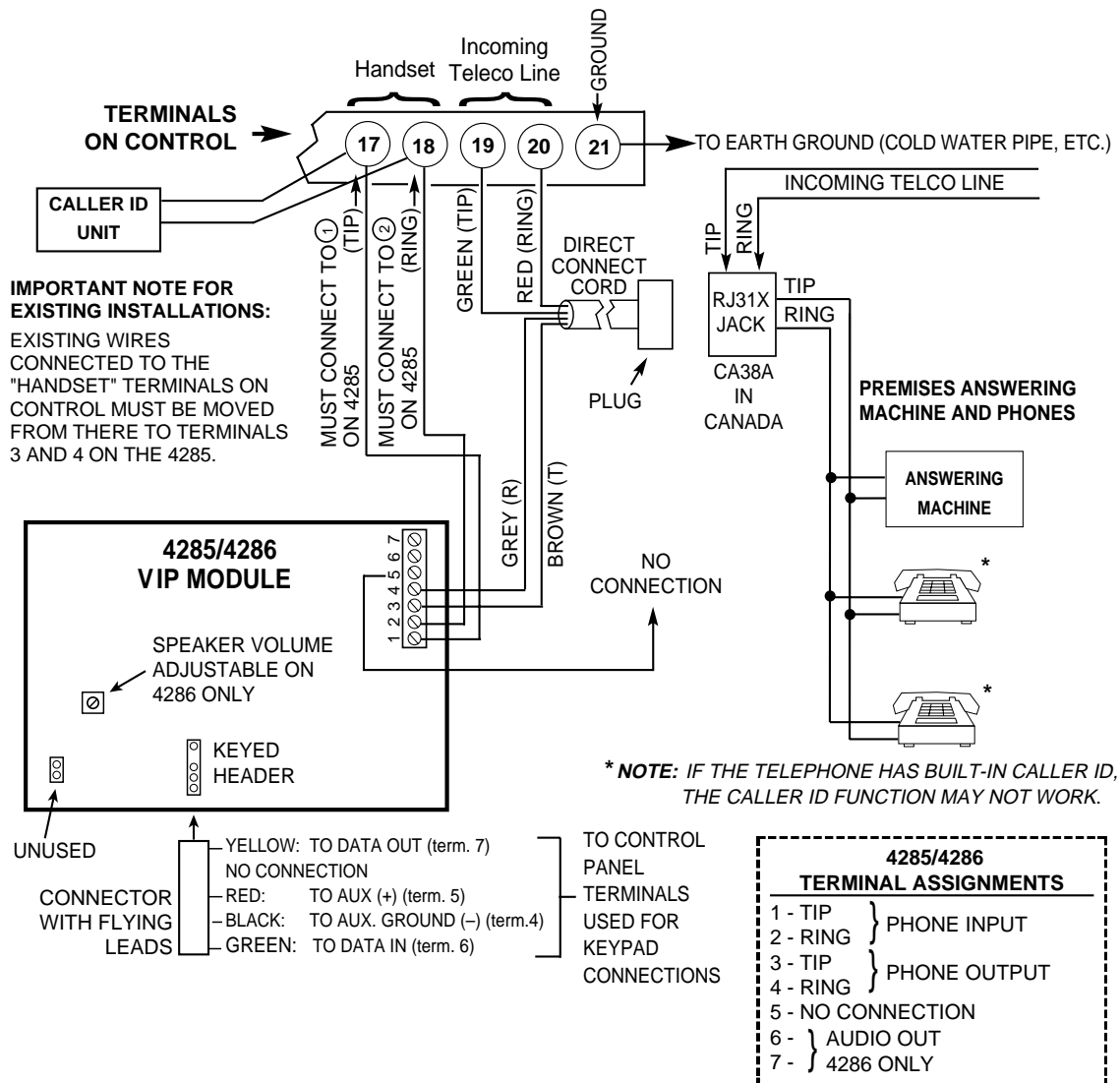

Figure 11. 4285/4286 VIP Module Wiring Connections

Programming the Control for Phone Access

To program the control for phone access using the 4285/4286 VIP Module, you must assign a VIP Module access code (★26) and ring detection count (★95). Also, you may optionally select words and/or form custom words that would be displayed on the keypad. Refer to *THE DATA FIELD DESCRIPTION* and *ALPHA DESCRIPTOR PROGRAMMING* sections for specific programming details.

Perform a preliminary check of the VIP Module, as indicated next.

Checking the Operation of the VIP Module

To Check VIP Module Operation From an On-Premises Phone

1. Pick up the phone and enter the programmed 2-digit VIP Module access code. Annunciation of a system status report should automatically start. See the User Guide accompanying the VIP Module for detailed information regarding the nature of the status report, if necessary.

2. During any pause in the status report, or immediately following it, key the following via the keypad on the phone:

4111 (Installer code) + 1 (OFF).

You should hear a beep on the phone and from a wired keypad. You should also hear the words, "**Disarmed...Ready to Arm**" or "**Disarmed...Not Ready to Arm**," indicating that the command was entered successfully. (The voice message, "**Disarmed...Not Ready to Arm**" indicates an open zone).

3. Hang up the phone.

To Check VIP Module Operation from an Off-Premises Phone:

1. Have someone dial the premises phone number, using a TouchTone phone.
 - If the phone system **does not** include an answering machine, the caller hears 2 long tones, followed by a voice prompt "**HELLO, ENTER PHONE CODE NOW.**" The caller must enter the programmed 2-digit phone code (entered in field ★28, PHONE MODULE ACCESS CODE).
 - If the premises phone system **includes** an answering machine, the 2-digit phone code must be entered **during a pause** at the beginning of, or during, the outgoing answering machine message. Then the caller hears a voice prompt asking for entry of the 4-digit system code ("**ENTER SYSTEM CODE NOW**").
2. The caller should then enter the Installer Code (4111). As a safety feature, there is a 3-try limit in which to enter each code (phone code and system code), after which time the call-in is aborted. Also, if no keys are pressed for a period of 20 seconds, the call-in is aborted.

Annunciation of a system status report will start if both codes were entered correctly.

3. During any pause in the status report, or immediately following it, the caller should key the following via the keypad on the phone:

Installer Code (4111), then **1 (OFF)**.

The caller should hear a beep from the phone and a wired keypad on the premises. The caller should also hear the words "**Disarmed...Ready to Arm**" or "**Disarmed...Not Ready to Arm**" on the phone, indicating that the command was entered successfully. "**Disarmed...Not Ready to Arm**" would indicate an open zone.

4. At this point, the caller can hang up the phone.
5. Verify with the caller that there was successful access to the system and that the appropriate voice announcements were heard over the phone.
6. If the VIP Module functioned satisfactorily, unplug the AC transformer from the AC outlet.

External Sounders

In This Section

- ◆ *Compatible Sounders*
- ◆ *NFPA Requirements*
- ◆ *Sounder Connections and Power*
- ◆ *Sounder Supervision*
- ◆ *Testing the Sounder*

Compatible Sounders

ADEMCO AB-12M 10" Motorized Bell & Box	Motor bell & box. UL Grade A. 100mA current draw.
ADEMCO 1011BE12M 10" Motorized Bell & Box	Motor bell & box. UL Listed. 100mA current draw.
ADEMCO 702 Outdoor Siren	Self-contained 6–12 volt siren (driver built-in) and weatherproof for outdoor use. Can be wired for either a steady or warble sound. 117dB @ 10 feet. 1500mA current draw.
ADEMCO 719 2-Channel Siren	Self-contained 6–12-volt siren (driver built in). Steady or warble sound. 109dB @ 10 feet. 550mA current draw.
ADEMCO 747 Indoor Siren	Self-contained 6–15 volt siren (driver built-in) for indoor wall mount. 747F available for flush mounting. 105dB @ 10 feet. 400mA current draw.
ADEMCO 747UL Indoor Siren	Self-contained 6–15 volt siren (driver built-in) for indoor wall mount. UL Listed. 85dB @ 10 feet. 320mA current draw.
ADEMCO 744 Siren Driver	6 jumper-selected sound outputs. Rated at 119dB with use of an 8-ohm 30 watt speaker. 1.3 amps current draw.
ADEMCO 745X3 Voice Siren Driver	12-volt voice siren driver with English, Spanish, and French voice messages. Separate messages for fire and burglary. Use with 8-ohm speaker. UL Listed. 1100mA current draw. NOTE: Requires special power wiring, using additional components.
ADEMCO 705–820, 5-inch Round Speaker	20-watt, 8-ohm indoor or outdoor speaker. Requires a driver.
ADEMCO 713 Speaker	40-watt, 8-ohm, indoor/outdoor speaker. Requires a driver.
System Sensor PA400B (beige)/PA400R (red) Indoor Piezo Sounder	Indoor piezo sounder (red or beige), rated at 90 dB @ 10 feet.



For UL installations, use only UL Listed sounding devices mounted indoors.

NFPA Requirements

The VISTA-10SE complies with NFPA requirements for temporal pulse sounding of fire notification appliances.

Temporal pulse sounding for a fire alarm consists of the following:

3 pulses – pause – 3 pulses – pause – 3 pulses . . .

Sounder Connections and Power

The VISTA-10SE provides a 12VDC output, which can power external alarm sounders, bells, or sirens (see table of compatible sounders on a previous page). This output activates a sounder when an alarm occurs.

Make connections to alarm output terminals 3 (+) and 4 (-). See *Figure 12* below.

UL

The total current drawn from the alarm output and the auxiliary power output, combined, cannot exceed 600mA. In addition, the sounding device must be a UL Listed audible signal appliance rated to operate in a 10.2-13.8VDC range. Example: Wheelock Signals Inc. siren model 34T-12 (provides 85dBA for NFPA 74 and Standard 985).

Non-UL Installations

The total current drawn from this output cannot exceed 2 amps. A battery must be installed because the battery supplies this current.



Going beyond the limits indicated (2 amps) will overload the power supply, and cause the electronic circuit protecting the sounder output to trip.

Sounder Supervision

The VISTA-10SE contains a sounder (Bell) supervision option. To activate the Bell supervision option:

1. Cut the red Bell Supervision Jumper located above terminals 2 and 3 on the control board. See *Figure 13* below.
2. Connect a 1k ohm resistor across the terminals of the **last** sounding device, **not** across the control's terminals.

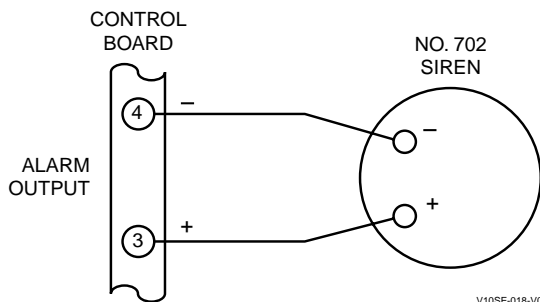

Figure 12. Typical Sounder Wiring

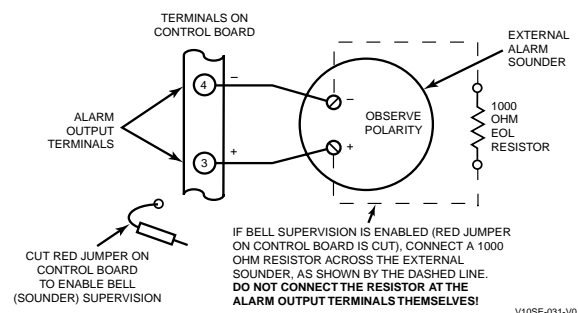

Figure 13. Bell Supervision Wiring

Testing the Sounder

After you install the sounder, test the security system carefully, as follows:

1. Connect the battery wires from the control board to the battery, observing correct polarity.
2. Enter the Installer code (4111) and press the TEST (5) key on the keypad.

The external sounder should sound for 1 second if the sounder is working and proper connections have been made. Note that if the backup battery is discharged, the sounder does not turn on.

3. To turn off the Test mode, enter the Installer code (4111) and press the OFF key.
4. Disconnect the battery wires from the battery terminals.
5. Unplug the AC transformer from the AC outlet.

Long-Range Radio

In This Section

- ◆ *About Long-Range Radio*
- ◆ *Wiring Connections*
- ◆ *Programming for Long-Range Radio*
- ◆ *Dynamic Signaling Feature*

About Long-Range Radio

If output to Long-Range Radio (LRR) is selected, all messages that are programmed to go to the primary telephone line receiver are also sent to any LRR that can operate in ECP mode. These messages (by telephone or radio) are sent in Contact ID format (not affected by entry in field *46).

UL

For UL installations, Long-Range Radio **must** be disabled (*27 = 0).

The data line is supervised, as well as certain functions in the radio. If communication is lost or a trouble develops, an attempt is made to send a message via both radio and telephone to the Central Station.

For complete information, see the manual that accompanies the radio.

Wiring Connections

Connect the data in/data out terminals and voltage terminals of the LRR being used, to the control's terminals as shown below.

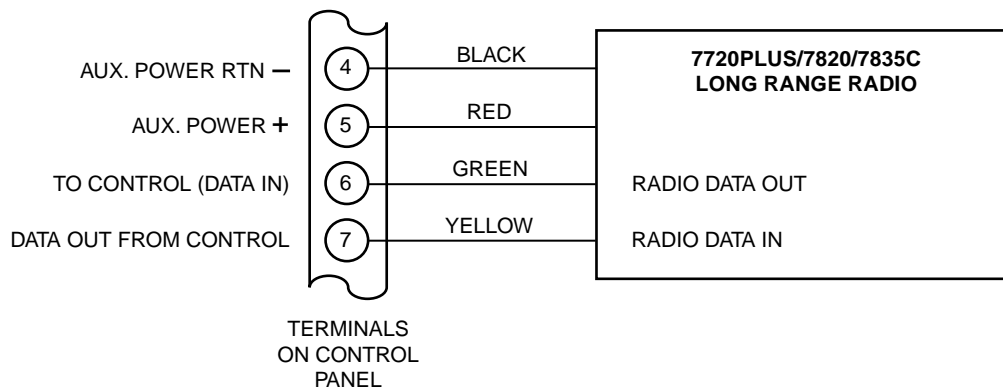

Figure 14. Long-Range Radio Connections

Programming for Long-Range Radio

Programming for the Long-Range Radio and/or Dynamic Signaling feature that follows is explained in the *DATA FIELD DESCRIPTIONS* section (fields *27 and *93).

Dynamic Signaling Feature

This VISTA-10SE control panel features **Dynamic Signaling Delay (DSD)** and **Dynamic Signaling Priority (DSP)** message reporting when Long-Range Radio is used. These message outputs are accessed through data field ✳93. The Dynamic Signaling feature is designed to reduce the number of redundant reports sent to the central station.

The features are described as follows:

- **Dynamic Signaling Delay (DSD)**

You can select the time the panel should wait for acknowledgment from the first reporting destination before it attempts to send a message to the second destination. Delays can be selected from 0 to 225 seconds, in 15-second increments. This choice is made by the first entry in field ✳93. *This delay is applicable to each individual message.*

- **Dynamic Signaling Priority (DSP)**

You can select the initial reporting destination for messages, Primary Dialer or Long-Range Radio. This choice is made by the second entry in field ✳93.

The chart below provides a concise explanation of how the Dynamic signaling feature functions.

If Priority (✳93, 2nd entry) is...	And message is...	Then...
Primary Phone No. ("0" entered)	Acknowledged before delay expires	Message is removed from queue and no message is sent to LRR.
	Not acknowledged before delay expires	Message is sent to both the Primary Phone Number and LRR.
Long-Range Radio ("1" entered)	Acknowledged before delay expires	Message is removed from queue and no message is sent to Primary Phone Number
	Not acknowledged before delay expires	Message is sent to both the Primary Phone Number and LRR.



You must enable field ✳27, OUTPUT TO LONG-RANGE RADIO, if this feature is to function.

Audio Alarm Verification (AAV) Unit

In This Section

◆ About Audio Alarm Verification

◆ Wiring Connections

About Audio Alarm Verification

An Audio Alarm Verification (AAV) module, such as the Eagle 1250, is an add-on accessory that permits voice dialog between an operator at a central station and a person at the alarm installation, for the purpose of alarm verification.



To enable the AAV feature, enter option “4” in field ★91 Option Selection (AAV), select Contact ID report format for the primary phone number, and program alarm reports for the primary phone number.

UL

The AAV option **cannot** be used in UL installations.

After all messages have been sent during a reporting session to the primary phone number, the control triggers the AAV if at least one of the messages was an Alarm report. The control sends a listen-in-to-follow message (Contact ID event code 606), which signals the 685 (the central station receiver) to hold the phone connection for 1 minute.

Once the digital message is “kissed off,” the control gives up the phone line to the AAV module, without breaking connection with the central station. At this time, all sirens and all continuous keypad sounds are shut off.



You must connect a 4204 Relay Module when using an AAV unit. Do not use relay output number 1 for any other function.

Wiring Connections

The AAV is triggered by a 4204 Relay Module, as shown in the AAV connection diagrams that follow in *Figures 15* and *16* (one diagram for connections when a 4285/4286 VIP Module is **not** used, the other when the 4285/4286 VIP Module **is** used).

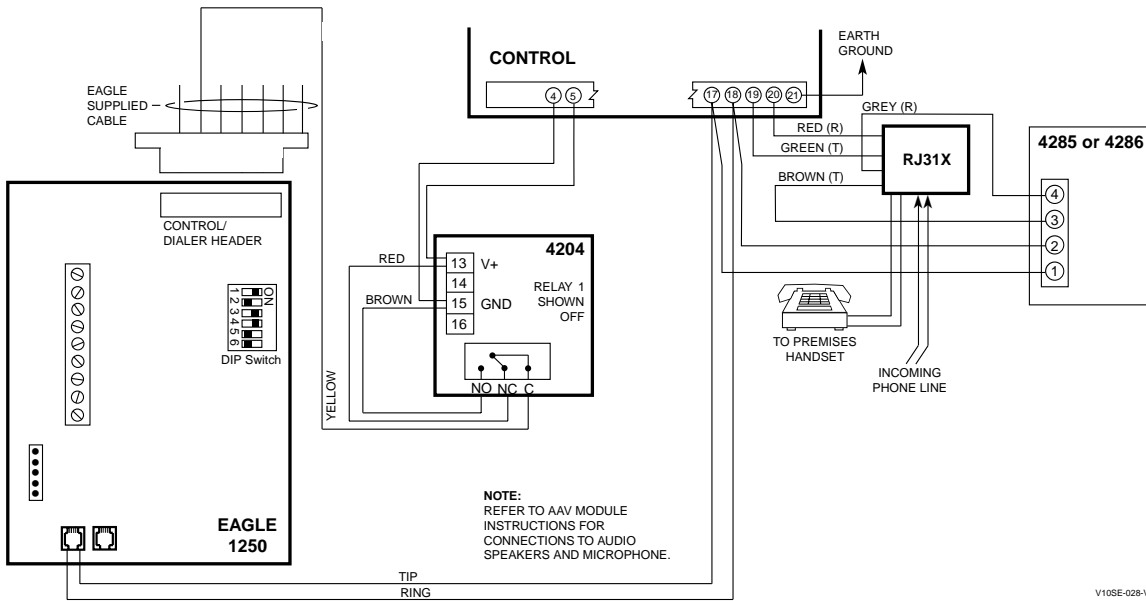
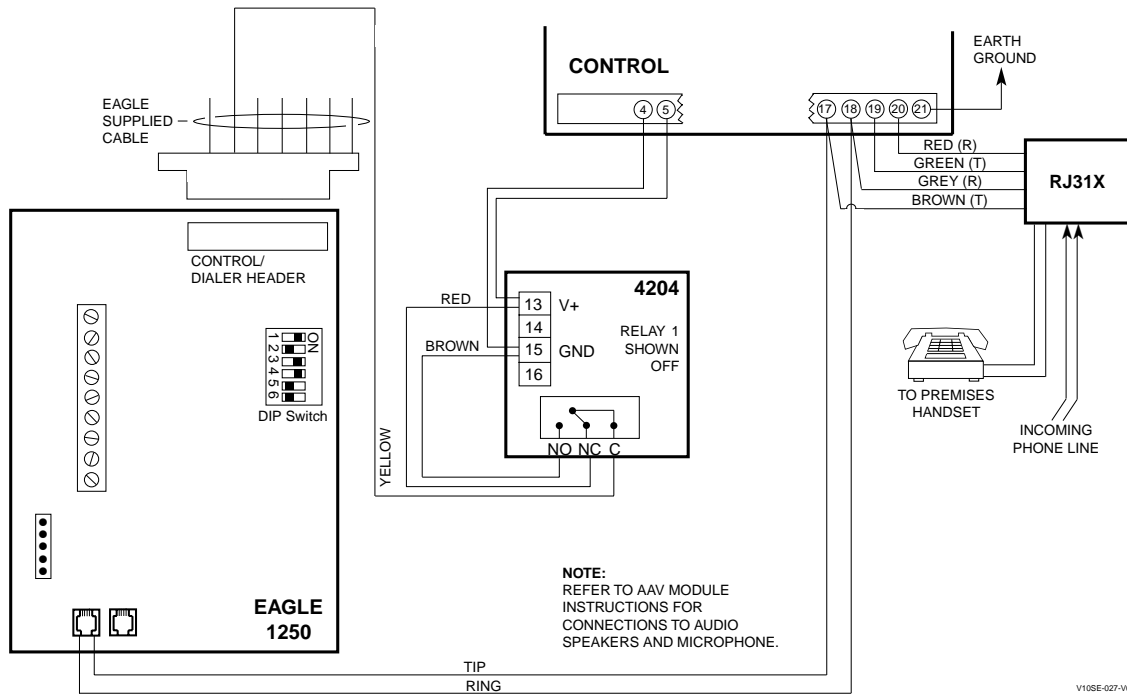

Final Power-Up

In This Section

- ◆ *Earth Ground Connections*
- ◆ *Calculating the Battery Size Needed*
- ◆ *Wiring the AC Transformer*
- ◆ *Connecting the Backup Battery*
- ◆ *AC Power-Up*
- ◆ *Battery Tests*

Earth Ground Connections

The designated earth ground terminal (21) must be terminated in a good earth ground for the lightning transient protective devices in this product to be effective.

The following are examples of good earth grounds available at most installations:

Metal Cold Water Pipe:

Use a non-corrosive metal strap (copper is recommended) firmly secured to the pipe to which the ground lead is electrically connected and secured.

AC Power Outlet Ground:

Available from 3-prong, 120VAC, power outlets only. To test the integrity of the ground terminal, use a three-wire circuit tester with neon lamp indicators, such as the UL-Listed Ideal Model 61-035, or equivalent, available at most electrical supply stores.

Wiring the AC Transformer

1321 Transformer

Wire the 1321 Transformer to terminals **1** and **2** on the control board. See wiring table below for wire gauge to use.

WIRING TABLE	
Distance of Transformer From the Control Panel	Wire Gauge to Use
Up to 50 feet	# 20
50 – 100 feet	# 18
100 – 250 feet	# 16



-
- Wiring to the AC transformer must not exceed 250 feet using 16 gauge wire.
 - Do not plug the transformer into the AC outlet until you are instructed to do so later in the manual.
-

AC Power-Up

To turn on AC power, perform the following steps:

1. Plug the 1321/1321CN into a 24-hour, unswitched 120VAC outlet.

Following power-up, one of the following is displayed on the keypad: **AC, dI** (disabled); **BUSY STANDBY** (on alpha keypads); or **NOT READY** (on fixed-word keypads). The green POWER LED (or READY LED on some keypads) should light.

2. After approximately 1 minute, the initial displays revert to **DISARMED...READY TO ARM** for alpha keypads, or **READY** for fixed-word keypads (if there are no faulted zones). This 1-minute delay allows PIRs, etc. to stabilize.

To bypass this delay, press: # + 0.

NOTE: If you do not get the “READY” displays described above, refer to “Trouble Conditions” in the *SYSTEM OPERATION* section.

Calculating the Battery Size Needed

Determine the total device current draw after filling in the AUXILIARY DEVICE CURRENT DRAW WORKSHEET that follows. To this figure add the 100mA that is drawn by the control panel itself. Then, to determine the battery size needed, use the following formula:

Total Current Drawn* x Number of hours standby wanted = Battery Ampere/Hours.

* Convert mA figure to decimal Amps (see example that follows).

Example: If total auxiliary device current drain is 450mA, add 100mA for the control panel, for a total of 550mA (0.55 amps); if 24-hour standby is wanted, the calculation is:

$$0.55A \times 24 \text{ hours} = 13.2 \text{ Ampere/Hour battery needed}$$

In this example, two 7 Amp/Hr batteries (connected in parallel) must be used.

AUXILIARY DEVICE CURRENT DRAW WORKSHEET

DEVICE	CURRENT	# UNITS	TOTAL CURRENT
6128 Keypad	30mA		
6139 Keypad	100mA		
5881/5882 RF Receiver	35mA		
4204 Relay Unit	15/180mA‡		
4285 VIP Module	160mA		
4286 VIP Module	300mA		
*			
*			
*			
TOTAL =			
Current available from Aux. terminals = 600mA max (500mA max for UL installations)**			

* If you are using hardwire devices such as PIRs, refer to the specifications for that particular unit's current draw.

** In UL installations, maximum current draw from the Auxiliary Output and the Alarm Output **combined** must not exceed 600mA.

‡ Figures are for relays de-energized (OFF)/relays energized (ON).

Connecting the Backup Battery

In the event of an AC power loss, the control panel is supported by a backup, rechargeable Sealed Lead Acid battery. The range of battery sizes recommended are: 12VDC; 4AH-17.2AH. See "Calculating the Battery Size Needed" earlier in this section. The battery is installed in the control cabinet.

Making the Battery Connections

1. Use the battery standby formula (above) to select the appropriate battery for the installation.



Do not connect the battery until all devices have been wired to the control.

2. Attach the red and black battery wires from the control board to the battery as follows:
 - Red to the positive (+) terminal on the battery.
 - Black to the negative (-) terminal on the battery.

UL

Use a 4AH battery or larger for UL installations. Calculate the actual battery size needed by referring to the proper paragraph in this section.

Battery Tests

The standby battery is automatically tested every 4 hours, beginning 4 hours after exiting Programming mode or after a system reset. In addition, entry into the Test mode causes a battery test to be initiated.

If the battery cannot sustain a load, a **LOW BATTERY** message is displayed and, if so programmed, is reported to the central station. In addition, the connection to the battery is checked every 3 minutes (a CSFM requirement). If there is no battery detected, or a low-battery condition is detected, a **LOW BATTERY** message is displayed and a report is sent to the central station.

Mechanics of Programming

In This Section

- ◆ *About Programming*
- ◆ *Entering Program Mode*
- ◆ *Programming a Data Field*
- ◆ *Reviewing a Data Field/Erasing an Entry*
- ◆ *Interactive Menu Mode Programming*
- ◆ *Loading Factory Defaults*
- ◆ *Programming System Setup Fields*
- ◆ *Exiting the Programming Mode*

About Programming

This section provides information on how programming is performed in this system. It will enable you to understand how to enter and exit the Programming mode, and how to program the data fields and the user-friendly Interactive Menu modes (*56, *58, *80, *81, *82). We therefore urge you to read and understand the following before proceeding with any programming.



If RF zones or relays are used, the following applicable program fields **must be** enabled before doing any zone programming:

- *22 RF SYSTEM
- *25 OUTPUT RELAY MODULE

It is possible to program the system at any time, even at the installer's premises prior to the actual installation. Simply apply power temporarily to the control and then program the unit as desired.



You cannot enter the Programming mode unless the security system is **disarmed**.

There are two programming modes: Data Field programming and Interactive (Menu) mode programming. Data Field programming is used for setting various system options. Interactive programming is used for programming zone information, programming relay outputs, inserting alpha descriptors (or custom words), and enrolling transmitter serial numbers.



To program the system, you must use a 6139 2-line alpha keypad connected to the keypad terminals on the control (4, 5, 6, and 7). **Remember, the security system must be disarmed.** The alpha keypad need not remain in the system after programming.

Programming can also be performed remotely from the installer's office/home, using an IBM personal computer, a modem, and COMPASS downloading software. See the **REMOTE PROGRAMMING AND CONTROL (DOWNLOADING)** section.

Entering the Program Mode

You may use one of the following methods:

- a) Press the [*] and [#] keys at the same time within 50 seconds after power is applied to the control; or
- b) After power-up, enter **4 1 1 1 (Installer code) + 8 0**.

This method is disabled if you exit the Program mode using *98 instead of *99. See the paragraph titled, "Exiting the Program Mode," later in this section.

If a different Installer code is subsequently programmed, use it instead of 4111 to gain access to the Programming mode.

When you enter the Program mode, data field *20 is displayed (this is the first data field in the system). The system now accepts entries for field *20.

Programming a Data Field

1. Press [*]+ **Field No.** (for example, *21), then make the desired entry.
2. When you have completely programmed a data field, the keypad beeps three times and then automatically displays the next data field in sequence. To go to a different field, press [*] plus the desired field number.
3. If the number of digits that you need to enter in a data field is less than the maximum digits available (for example, the phone number field), enter the desired data, then press [*] and the next data field number to be programmed.
4. If you try to enter a nonexistent field, the keypad will display **NOT USED EE** (Entry Error). Simply re-enter [*] plus a valid field number.

Reviewing a Data Field/Erasing an Entry

Press [#] + **Field No.** Data is displayed for that field number. **No changes are accepted in this mode.**

To delete an entry in a field, press [*] + **Field No.** + [*] (applies only to fields *40-*43, and *94).

Interactive Mode Programming (*56, *58, *80, *81, and *82)

Typical prompt displayed during Interactive mode programming:

Enter Zn Num. (00 = Quit) 01
--

Zone Number ↑

Press [*] + **Interactive Mode No.** (for example, *56). The alpha keypad displays the first of a series of prompts requesting entries.

A detailed procedure (with displays of prompts) is provided in later sections of this manual.

Interactive Mode	Used to Program
*56 Zone Programming	Zone characteristics, report codes, alpha descriptors, and serial numbers
*58 Expert Mode Programming	Zone characteristics, report codes, and serial numbers.
*80 Output Relay Programming	4204 Relay module
*81 Zone List Programming	Zone lists for relay control
*82 Alpha Programming	Zone alpha descriptors

Loading Factory Defaults

To load the factory defaults, enter the Programming mode, press *97, then exit the Programming mode.



Do not press *97 to load defaults if any programming has been done previously. If you do, data already programmed into the system will be changed!

*96 resets all the subscriber account numbers and CSID in preparation for an initial download.

Exiting the Programming Mode

*99 allows re-entry into the Program mode using **Installer Code + 8 0**.

*98 prevents re-entry into the Programming mode using the Installer code.

Zone Response Type Definitions

In This Section

◆ Zone Type Definitions

Zone Type Definitions

You must assign to each zone a zone type that defines the way in which the system responds to faults in that zone. Zone types are defined below.

Type 00 Zone type 00 is used to program a zone that is not used.
Zone Not Used

Type 01 Zone type 01 is usually assigned to sensors or contacts on primary entry and exit doors.
Entry/Exit Burglary



Zone Characteristics:

- Entry delay #1 is programmable from 0-99 seconds (field *35).
- Exit delay is independently programmable from 0-99 seconds (field *34).
- Exit and entry delays when armed in AWAY or STAY mode.
- No entry delay when armed in INSTANT or MAXIMUM mode.
- Exit delay regardless of the arming mode selected.

Type 03 Zone type 03 is usually assigned to all sensors or contacts on exterior doors and windows.
Perimeter Burglary



Zone Characteristics:

- Instant alarm when armed in AWAY, STAY, INSTANT, or MAXIMUM mode.

Type 04 Zone type 04 is usually assigned to a zone covering an entry area (i.e.: foyer, lobby, or hallway) that one must pass upon entry (after faulting the entry/exit zone) to reach the keypad. It provides an instant alarm if the entry/exit zone is not violated first, and protects an area in the event an intruder has hidden on the premises before the system is armed, or gains access to the premises through an unprotected area.
Interior, Follower



Zone Characteristics:

- Delayed alarm (using the programmed entry/exit time) if entry/exit (type 01) or interior-with-delay (type 10) zone is faulted first.
- Instant alarm in all other situations.
- Active when armed in AWAY or MAXIMUM mode.
- Bypassed automatically when armed in STAY or INSTANT mode.

Type 05
**Trouble by Day/
Alarm by Night**

Zone type 05 is usually assigned to a zone that contains foil-protected doors or windows; or covers a sensitive area (e.g., stock room, drug supply room, etc.) It can also be used on a sensor or contact in an area where immediate notification of an entry is desired.

Zone Characteristics:

- Provides an instant alarm when armed in AWAY, STAY, INSTANT, or MAXIMUM (night) mode.
- Provides a latched trouble sounding from the keypad and, if desired, a central station report during the disarmed state (day).

Type 06
24-hour Silent Alarm

Zone type 06 is usually assigned to a zone containing an Emergency button.

Zone Characteristics:

- Sends a report to the central station but provides no keypad display or sounding.

Type 07
24-hour Audible Alarm

Zone type 07 is usually assigned to a zone containing an Emergency button.

Zone Characteristics:

- Sends a report to the central station, and provides alarm sounds externally and at the keypad.

Type 08
**24-hour
Auxiliary Alarm**

Zone type 08 is usually assigned to a zone containing a button for use in personal emergencies or to a zone containing monitoring devices (e.g., water or temperature sensors, etc.).

Zone Characteristics:

- Sends a report to the central station and provides an alarm sound at the keypad. (No bell output is provided and there is no keypad timeout.)

Type 09
Supervised Fire

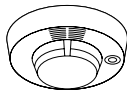

5806/5807/5808
01000-020-10

Zone type 09 can be assigned to any wireless zone used as a fire zone. This zone type is always active and cannot be bypassed.

Zone Characteristics:

- Bell output will pulse when this zone type is alarmed.

Type 10
Interior w/Delay

Zone type 10 is bypassed when the panel is armed in the STAY or INSTANT mode.

Zone Characteristics:

- Entry delay #1 (with programmed entry time) when armed in the AWAY mode.
- Entry delay begins whenever sensors in this zone are violated, regardless of whether an entry/exit delay zone was tripped first.
- No entry delay when armed in the MAXIMUM mode.
- Exit delay regardless of the arming mode selected.

Type 20 Zone type 20 is a special-purpose zone type used with 5800 Series wireless pushbutton transmitters.
Arm-STAY

Zone Characteristics:

- Exit delay regardless of the arming mode selected.
- System is armed in the STAY mode when the zone is activated.
- Zone number is sent to the central station as a user number when arming or disarming.

Type 21 Zone type 21 is a special-purpose zone type used with 5800 Series wireless pushbutton units.
Arm-AWAY

Zone Characteristics:

- System is armed in the AWAY mode when the zone is activated.
- Zone number is sent to the central station as a user number when arming or disarming.

Type 22 Zone type 22 is a special-purpose zone type used with 5800 Series wireless pushbutton.
Disarm

Zone Characteristics:

- Disarms the system when the zone is activated.

Type 23 Zone type 23 can be used when the action of a relay is desired, but with no accompanying alarm (e.g., a front or back door light being turned on or off).
No Alarm Response

Data Field Descriptions

In This Section

◆ Descriptions of System Data Fields

NOTE: The following program field **must be** programmed before doing any zone programming:

*22 RF SYSTEM

Descriptions of System Data Fields

The blank programming form (separate insert) should be used to record the data for this installation. Defaults for any field (where applicable) are indicated beside the blank data entry box for each field.

The following is a list of all data fields in this control (presented in numerical order). This list provides an explanation of each data field, and will serve as a reference for all fields in the system.

- *20 INSTALLER CODE** (4-Digit Entry)
 The Installer code is used to program the system, and to assign the 4-digit Master Security Code **in the normal operation mode**, via the keypad. See "Master Code" in the *SYSTEM OPERATION* section for the procedure. Enter 4 digits, 0–9.
- *21 QUICK ARM ENABLE** (1-Digit Entry)
 If enabled, the [#] key can be used instead of the security code when **arming** the system. Enter 0 for disabled or 1 for enabled. **This feature will function only if the Master Code is programmed.**
- *22 RF SYSTEM** (1-Digit Entry)
 This option is enabled if a wireless receiver is used.
 Enter 1 for a 5800 RF system (5881* Series RF receivers), 4 for a 5800 RF system, but with RF jam detection. Enter 0 if no receiver is being used.
 * 5882 Series RF receivers in Canada.
- *23 FORCED BYPASS** (1-Digit Entry)
 This feature allows all faulted zones to be bypassed automatically.
 All zones that are bypassed by this function will be displayed after the bypass is initiated:
 0 = No forced bypass; 1 = Allows automatic bypass of all open zones.
- *24 RF HOUSE ID CODE** (2-Digit Entry)
 If a 5827 or 5827BD Wireless Keypad is to be used in a 5800 RF system, a House ID code **MUST** also be entered (01–31), and the keypad should be set to the same ID. In a 5800 system with no 5827 or 5827BD wireless keypad, enter 00 (no House ID).
- *25 OUTPUT RELAY MODULE** (1-Digit Entry)
 Enter 3 if relay module is being used, or 0 if not.

- *26 VOICE (PHONE) MODULE ACCESS CODE** (2-Digit Entry)
The use of a 4285 or 4286 VIP (Phone) Module requires a 2-digit code. Enter a 2-digit phone access code as follows: For first digit, enter any digit from 1 to 9; for second digit, enter # +11 for *, or # +12 for #.

Example: If the desired access code is 7*, 7 is the first entry, and # + 11 (for *) is the second entry.

00 = VIP Module disabled. **Note:** A 0 in *either* digit will disable the 4285/4286 VIP Module.

- *27 OUTPUT TO LONG-RANGE RADIO** (1-Digit Entry)
0= no, 1 = yes. If output to LRR is selected here (1), all messages that are programmed to go to the primary telephone line receiver will also be sent to the radio (e.g., 7720 PLUS). These messages will always be in Contact ID format (overriding the selection in field *46). The data line is supervised, as well as certain functions in the radio.

If communication is lost or a trouble develops, the system will attempt to send a message via both radio and telephone to the central station.

Normal trouble restore report (*71) is sent on restore of the condition.

NOTE: The Radio should be programmed for device address 3 on the keypad lines.

**ZONE SOUNDS
AND TIMING
(*28-*39)**

- *28 SINGLE ALARM SOUNDING PER ZONE
(Per Armed Period)** (1-Digit Entry)
This field limits external alarm sounding to once per arming period for a given zone. Enter 1 for yes; 0 for no.
UL installations: Enter 0 for unlimited alarm soundings.

- *29 FIRE SOUNDER TIMEOUT** (1-Digit Entry)
This field determines whether the external sounder will shut off after time allotted, or continue until manually turned off.
Enter 0 for sounder timeout, or 1 for no timeout.
Default is 0.

- *30 ALARM BELL TIMEOUT** (1-Digit Entry)
This field determines whether the external sounder will shut off after time allotted, or continue until manually turned off. Enter as follows:
0 = No timeout; 1 = 4 min (default); 2 = 8 min; 3 = 12 min; 4 = 16 min.

- *38 ENTRY DELAY** (1-Digit Entry)
System will wait the time allotted before sounding alarm upon entering. May be selected individually.
0 = 0 seconds; 1 = 20 seconds; 2 = 30 seconds; 3 = 45 seconds;
4 = 60 seconds; 5 = 90 seconds.
UL installations: Entry delay can be no greater than 45 seconds (3).
(EXIT delay = Entry delay plus 15 seconds).

**DIALER
PROGRAMMING
(*40-*50)**

Fields *40, *41, *42:
Enter up to the number of digits shown. Do not fill unused spaces.
Enter 0-9,
+ 11 for *
+ 12 for #
+ 13 for a pause
(2.5 secs)

- *39 AUDIBLE EXIT WARNING** (1-Digit Entry)
If enabled, this field provides exit warning sound when armed AWAY or MAXIMUM.
Warning sound consists of slow continuous beeps until last 5 seconds, when it changes to fast beeps. The warning sound will end at the termination of Exit time.
0 = no; 1 = yes.
- *40 PABX ACCESS CODE** (See box at left.)
Enter up to 4 **digits** if PABX is needed to access an outside line. If fewer than 4 digits are needed to be entered, exit by pressing * nd next field number (e.g., 41). To clear entries from field, press *40*.
- *41 PRIMARY PHONE NO.** (See box at left.)
Enter up to 12 digits. If fewer than 12 digits entered, exit by pressing * and next field number (e.g., 42). To clear entries from field, enter *41*.
NOTE: Backup reporting (8 calls are made to the secondary phone number if no kiss-off is received after 8 attempts to primary number) is automatic only if there is a secondary phone number (field *42).
- *42 SECONDARY PHONE NO.** (See box at left.)
Enter up to 12 digits. If fewer than 12 digits entered, exit by pressing * and next field number (e.g., 43). To clear entries from field, enter *42*. See NOTE in field *41 also.
NOTE: If you wish to send a report to a pager, see field *47 on a following page .
- *43 SUBSCRIBER ACCOUNT NO.** (Enter up to 4 digits)
Enter digits 0-9, #+11=B, #+12=C, #+13=D, #+14=E, or #+15=F. Enter * as the fourth digit if a 3-digit account no. (for 3+1 dialer reporting format) is used. Enter 0 as the first digit of a 4-digit account no. for nos. 0000-0999. End field by pressing * (and press next field) if only 3 digits are used.
This field is also used as the Long-Range Radio Subscriber Account No.
- *45 PHONE SYSTEM SELECT** (1-Digit Entry)
If central station receiver *is not* on WATS line:
0 = Pulse Dial;
1 = Tone Dial
If central station receiver *is* on WATS line:
2 = Pulse Dial
3 = Tone Dial

For an explanation of these formats, see the *SYSTEM COMMUNICATION* section.

***46 REPORT FORMAT** (1-Digit Entry)

Determine which format is to be used to report to the central station. Enter 1 digit (0–9).

0 = 3+1; 4+1 ADEMCO Lo Speed Standard (this is the default)

1 = 3+1; 4+1 Radionics Standard

2 = 4+2 ADEMCO Lo Speed Standard

3 = 4+2 Radionics Standard

6 = 4+2 ADEMCO Express

7 = ADEMCO Contact ID Reporting

8 = 3+1; 4+1 ADEMCO Lo Speed Expanded

9 = 3+1; 4+1 Radionics Expanded

(Enter * as the 4th digit of *43 if 3+1 dialer reporting is to be used.)

NOTE: The maximum number of alarm and alarm restore reports during one armed period is determined by field *92.

See field *27, which may override this field's selection.

***47 SPLIT/DUAL REPORTING** (1-Digit Entry)

Enter 0 to disable (backup report only).

Entries 1 through 9 can be made, as indicated in the table below. Entries 6 through 9 will send a report to a pager (in addition to the selected primary phone number), *but you must enter the pager number as the secondary phone number in field *42.*

	TO PRIMARY PHONE NO.	TO SECONDARY PHONE NO.
1 =	Alarms, Restore, Cancel	Other Reports
2 =	All except Open/Close, Test	Open/Close, Test
3 =	Alarms, Restore, Cancel	All reports
4 =	All except Open/Close, Test	All reports
5 =	All reports	All reports
	TO PRIMARY PHONE NO.	TO PAGING NO.* (Secondary)
6 =	All reports except Open/Close	Alarms/Open/Close, Troubles
7 =	All reports	Alarms, Troubles
8 =	All reports	Alarms/Open/Close, Troubles
9 =	All reports except Open/Close	Alarms, Open/Close for users #5–25‡, Troubles

* Can only be used if the Primary reporting format is ADEMCO Contact ID.
If reporting to a Pager, choose from 6, 7, 8, or 9, as desired.

‡ Will report only Users 5, 6 and 8. If using 5800 Series wireless button-type devices, the zone number of the arm or disarm button (10–25) will be sent as the user number.

Entries 6 through 9 will send a report to a pager (in addition to the selected primary phone number), but you must enter the pager number as the secondary phone number in field *42.

A 10-digit code is sent to the pager that is coded in the following format:
 4-digit Subscriber No. SSSS-EEE-NNN 3-digit User or Zone No.
 (as entered in field *43)

3-Digit Event Code (EEE), as follows:

911 = Alarm (NNN = Zone No.)

001 = Open, System disarmed (NNN = User No.)

002 = Close, System armed (NNN = User No.)

811 = Trouble (NNN = Zone No.)

NOTE: The first digit of the Subscriber No. entered in field *43 must be 1–9 (do not use 0); the last 3 digits can be 0–9. **Failure to observe this requirement may interfere with paging services.**

Example 1. Pager displays: 1234–911–004

This indicates that Subscriber No. 1234’s system is reporting an Alarm (911), due to zone 4 being faulted (004).

Example 2. Pager displays: 1234–001–005

This indicates that Subscriber No. 1234’s system is reporting an opening (001) by User 5 (005).

Note that no Restore Reports are sent to the pager.

Important: AAV should not be used when Paging or Alarm Reports are being sent to a secondary number. If this is done, the call to the secondary number by the communicator after the Alarm Report will prevent the AAV from taking control of the telephone line, and the AAV “Listen in” session cannot then take place.

***48 15-SECOND DIALER DELAY (BURGLARY) 1-Digit Entry**

If selected, will provide 15-second delay of Burglary Alarm Report to the central station. Allows time for subscriber to avoid a false alarm transmission.

0 for no delay, or 1 for 15-second delay.

***49 PERIODIC TEST REPORT (1-Digit Entry)**

Select the desired test report interval.

0 = none; 1 = 24 hours; 2 = weekly; 3 = 30 days.

Test Report code entered in field *64 is sent; reports with Subscriber No.

UL installations: 24 hours (1) must be selected.

***50 SESCOA/RADIONICS SELECT (1-Digit Entry)**

0 = Radionics (0–9, B–F reporting)

1 = SESCOA (0–9 only reporting)

Select 0 for all other formats.

***51 CONFIRMATION OF ARMING DING (1-Digit Entry)**

Enter 1 to enable 1/2-second external alarm sounding “ding” when closing report goes in, or at the end of exit delay. Enter 2 for alarm sounding ding with RF arming (this will work with either a button RF unit or a 5827).

0 disables the “ding.”

***52 ZONE 3 RESPONSE TIME TO OPEN** (1-Digit Entry)
 0 = 400mS nominal; 1 = 10mS nominal.

***56 ZONE ASSIGNMENT/ALARM REPORT CODES**

This is an Interactive Menu mode that is used to program **zone numbers, zone types, and alarm and report codes**, and to **identify the type of loop input device**.

This mode can also be used for entering 5800 Series transmitter serial numbers (serial numbers can also be entered using the Expert Programming Mode in *58).

Alpha descriptors can also be entered for zones in *56 (alternatively, alpha descriptors can be entered in menu mode *82).

***58 EXPERT PROGRAMMING MODE**

Interactive Menu mode used for enrolling transmitters, programming zone attributes, and report codes. Refer to the *ZONE PROGRAMMING* section for procedure.

Refer to the *BASIC HARDWIRED ZONES 1-6* section for detailed hardwired zone programming, and the *WIRELESS EXPANSION (5800 SYSTEM)* section for detailed wireless zone expansion programming.

Refer also to the zone assignment table for *56 in the Programming Form inserted in this manual.

TO PROGRAM SYSTEM STATUS AND RESTORE REPORT CODES (*60 - *68, *70 - *75)

With a 3+1 or 4+1 Standard Format: Enter a code in the *first digit* box: 1-9, 0, B, C, D, E, or F.

Enter # + 10 for 0, # + 11 for B, # + 12 for C, # + 13 for D, # + 14 for E, # + 15 for F.

A 0 (*not* # + 10) in the *first digit* box will disable a report.

A 0 (*not* # + 10) in the *second digit* box (if any) will result in automatic advance to the next field when programming.

With an Expanded or 4+2 Format: Enter codes in *both* boxes (1st and 2nd digits) for 1-9, 0, or B-F, as described above.

A 0 (*not* # + 10) in the *second* box will eliminate the expanded message for that report

A 0 (*not* # + 10) in *both* boxes will disable the report.

With ADEMCO Contact ID Reporting: Enter any digit (other than 0) in the *first* box, to enable zone to report This is an "enabling" code only and is disregarded in the actual reporting to the central office. Entries in the *second* boxes will be ignored.

A 0 (*not* # + 10) in the *first* box will disable the report.

Examples:

For Code **3** (single digit), enter:

For Code **32** (two digits), enter:

For Code **B2** (hexadecimal) enter:

- SYSTEM STATUS REPORT CODES** *60 **TROUBLE REPORT CODE** (See box above.) (2-Digit Entry)
- (*60 –*68) *61 **BYPASS REPORT CODE** (See box above.) (2-Digit Entry)
- *62 **AC LOSS REPORT CODE** (See box above.) (2-Digit Entry)
- Reports with Subscriber No. Timing of this report is random with up to a 48-minute delay. The Restore Report has a random delay of up to about 12 minutes. If AC restores before the report goes out, there is no AC Restore Report.
- *63 **LOW BAT REPORT CODE** (See box on previous page.) (2-Digit Entry)
- Reports with Subscriber No.
- *64 **TEST REPORT CODE** (See box on previous page.) (2-Digit Entry)
- Periodic Reports with Subscriber No.
- *65 **OPEN/EXIT ALARM REPORT CODE, 1st DIGITS** (2-Digit Entry)
- Open Report Code:** To enable, enter a code (or 0 to disable) in the left-hand box (see box above).
- For expanded or 4+2 reporting, 2nd digit = User No.*
- Exit Alarm Report Code:** To enable, enter a code (or 0 to disable) in the right-hand box (see box above). If enabled, **any alarm from an exit or interior zone occurring within two minutes after the end of the exit delay** will send a special message indicating exit alarm to the central station, and a zone indication and "Exit Alarm" or "EA" is displayed on the keypad.
- If an exit or interior zone contains a fault as the exit delay ends**, the local bell and keypad sound continuously.
- a) *If the subscriber then disarms the system before the ensuing ENTRY delay ends*, no message is transmitted to the central station, but a zone indication and "Canceled Alarm" or "CA" is displayed on the keypad.
- b) *If the system is not disarmed before that entry delay ends*, a special message indicating Exit Alarm is sent to the central station and a zone indication and "Exit Alarm" or "EA" is displayed on the keypad.
- For expanded or 4+2 reporting,* a 2nd digit is sent, and is the same as the 2nd digit of the zone Alarm Report code programmed in field *56.
- For Contact ID reporting,* Event code 374 and the zone number is sent.
- There is no restore message for an Exit Alarm report.
- *66 **AWAY/STAY CLOSE REPORT CODE** (2-Digit Entry)
- (See box on previous page.)
- To enable, enter a code (or 0 to disable) in either or both boxes.
- For expanded or 4+2 reporting, 2nd digit for each = User No.*
- *67 **RF XMTR. LOW BATTERY REPORT CODE** (2-Digit Entry)
- (See box on previous page.)
- *68 **CANCEL REPORT CODE** (2-Digit Entry)
- (See box on previous page.)

**RESTORE
REPORT CODES
(*70 - *75)**

- *70 ALARM RESTORE REPORT CODE**
(See box on previous page). For expanded or 4+2 reporting, a 2nd digit is automatically sent, and is the same as the 2nd digit of the zone Alarm Report code programmed in field *56.
- *71 TROUBLE RESTORE REPORT CODE** (2-Digit Entry)
(See box on previous page.) This is sent when a trouble in a zone is restored.
- *72 BYPASS RESTORE REPORT CODE** (2-Digit Entry)
(See box on previous page.) This is sent when a zone that has been bypassed is unbypassed.
- *73 AC RESTORE REPORT CODE** (2-Digit Entry)
(See box on previous page.) Reports with Subscriber No.
- *74 LOW BAT RESTORE REPORT CODE** (2-Digit Entry)
(See box on previous page.) Reports with Subscriber No.
- *75 RF XMTR. LOW BATTERY RESTORE CODE** (2-Digit Entry)
(See box on previous page.) This is sent when a transmitter that previously sent in a low-battery message has sent a message indicating it no longer has a low-battery condition.
- *80 OUTPUT RELAYS**
This is an Interactive Menu mode that is applicable only if 4204 relays are to be used ("3" in field *25). See the *RELAY OUTPUT DEVICES* section for a detailed programming procedure. Also refer to the OUTPUT RELAYS TABLE FOR FIELDS *80 and *81 in the Programming Form inserted in this manual.
- *81 ZONE LISTS FOR OUTPUT DEVICES**
This is an interactive menu mode that is applicable only if field *25 is programmed for a 4204 relay. Refer to the *RELAY OUTPUT DEVICES* section for a detailed programming procedure. Also refer to the ZONE LISTS FOR OUTPUT RELAYS table for *81 in the Programming Form inserted in this manual.
- *82 CUSTOM ALPHA EDITING**
See the *ALPHA DESCRIPTOR PROGRAMMING* section for procedure.
- *91 OPTION SELECTION** (1-Digit Entry)
Enter "4" if an Audio Alarm Verification (AAV) unit is connected in the system; enter "8" for Exit Delay Restart; enter "# +12" for AAV + Exit Delay Restart. Enter "0" if an AAV unit is not being used.
For UL installations, the AAV option must be disabled (0).
Important: AAV should not be used when Paging or Alarm Reports are being sent to a secondary number. If this is done, the call to the secondary number by the communicator after the Alarm Report will prevent the AAV from taking control of the telephone line, and the AAV "Listen-in" session cannot take place.
- *92 NUMBER OF REPORTS IN ARMED PERIOD** (1-Digit Entry)
This option can be used to limit the number of messages (Alarm and Alarm Restore Reports) sent to the central station in an armed period. "0" limits reports to a total of 10; "1" allows an unlimited number of reports.
UL installations: Must select "1."

***93 DYNAMIC SIGNALING DELAY (DSD) (1st entry)**

This field enables you to select the time the panel should wait for acknowledgment from the first reporting destination before it attempts to send a message to the second destination. Delays can be selected from 0 to 225 seconds, in 15-second increments.

This delay is per message.

0–15 times a 15-second delay. e.g., 1 = 15 seconds, 2 = 30 seconds, etc. Default is “0” (no delay). You must enter “0” for UL installations.

NOTE: If “0” is entered in this field, the control panel sends redundant reports to both Primary phone number and LRR.

DYNAMIC SIGNALING PRIORITY (DSP) (2nd entry)

This field enables you to select the initial reporting destination for messages, Primary Phone Number or Long-Range Radio.

0 = Primary Phone Number first; 1 = Long-Range Radio (LRR) first.

Default is “0” (Primary Phone Number)

**DOWNLOAD
INFORMATION
(*94, *95)**

***94 DOWNLOAD PHONE NUMBER**

Enter up to 12 digits; 0–9, # +11 for “*”, # + 12 for “#”, # + 13 for a pause. Do not fill unused spaces. End field by entering *. To clear entries from field, press *94*.

***95 RING DETECTION COUNT FOR DOWNLOADING**

Enter number of rings before control picks up phone line (0 to 15). Refer to the chart below and program this field accordingly.

VIP Module	Answering Machine	Downloading	Field *95
Yes	No	No	Set for value other than 0 (1–14). This will enable the control panel to answer the phone call. Otherwise, it will not be possible to access the VIP Module.
Yes	Yes	No	Set for a value higher than the number of rings for which the answering machine is set. Example: If machine is set for 4 rings, use a value of 5 or higher. This is recommended so that the VIP Module can still be accessed if the answering machine is turned off and does not answer the phone call.
Yes	No	Yes	Set for value other than 0 (1–14).
Yes	Yes	Yes	Enter 15 to bypass answering machine.
No	No	No	Enter 0.
No	No	Yes	Enter 1–14.
No	Yes	Yes	Enter 15. See Important Note below.

Important Note: If "15" is entered in field *95 to bypass an answering machine, and a 4285/4286 VIP Module is included in the installation, you should note the following:

When calling in from an off-premises phone (to receive a status report or execute a command), the user should make the initial call, allow 1 to 3 rings only, and hang up. Then call in again. The VIP Module will now seize the line, and 2 long tones will be heard, followed by the usual voice prompt for the 2-digit phone access code. If this procedure is not followed, VIP Module operation will not be possible.

- | | |
|--|--|
| TO EXIT
PROGRAMMING
MODE
(*98 or *99) | <p>*96 INITIALIZE DOWNLOAD ID AND SUBSCRIBER ACCT. NO.
FOR DOWNLOADING (No data entry required; press *96)</p> <p>*97 SET ALL PROGRAM FIELDS TO DEFAULT VALUES
(No data entry required; pressing *97 automatically loads all ADEMCO defaults). Do not use if previously programmed with other values.</p> <p>*98 EXITS PROGRAMMING MODE and <i>prevents</i> re-entry by :
INSTALLER Code + 8 + 0.
To enter the Programming mode if *98 was used to exit, you must first power the system down. Then power-up again, and depress [*] and [#] both at once, within 50 seconds of powering up.</p> <p>*99 EXITS PROGRAMMING MODE and <i>allows</i> re-entry by:
INSTALLER Code + 8 + 0 or by method described in paragraph above (power down, power-up and depress [*] and [#] both at once, within 50 seconds of powering up).</p> |
|--|--|

Zone Programming

(★56/★58 Menu Mode)

In This Section

- ◆ About Zone Programming
- ◆ ★56 Zone Programming Mode Procedures
- ◆ ★58 Expert Programming Mode Procedures
- ◆ To Remove a Zone
- ◆ To Delete a Transmitter Serial Number
- ◆ To Enter and Duplicate Wireless Keys

About Zone Programming

★56 Zone Programming and ★58 Expert Programming are Interactive Menu modes that are used to program zone numbers, alarm codes, and report codes, and to identify the type of input device. These modes can also be used for "enrolling" 5800 Series RF Wireless Transmitter serial and loop numbers. ★56 Zone Programming can be used for entering alpha descriptors for zones (we recommend entering descriptors in menu mode ★82). Refer to the zone assignment table for ★56 and ★58 on the separate Programming Form.

★56 Zone Programming Mode Procedures

NOTE: Before proceeding, you must program field ★22 (RF System) as required.

In the Programming mode, press ★56.

SET TO CONFIRM? 0 = NO 1 = YES 0

This display appears upon entry into ★56 mode. The default is **0** (No). If you enter **1** (Yes), you are prompted to confirm each transmitter after entering the serial and loop numbers (at the **XMIT TO CONFIRM** prompt later in this procedure).

We recommend that you confirm the programming of every transmitter.

Enter Zn Num. (00 = Quit) 10
--

Zone Number (Zn): Enter the zone number that you wish to program.

Zone 10 has been entered as an example in display at left.

Zone 10 entered ↑

Press [★] to continue.

ZN ZT RC IN: L 10 00 10 RF: -

A summary display appears, showing the status of that zone's programming when using wireless keys.

NOTE: If you are programming hardwired zones 01-06, the display appears as follows.

Zn ZT RC In: L 02 00 10 HW: -

Press [★] to continue.

↓ Zone Number

10 Zone Type	
Perimeter	03

Zone Type ↑

Zone Type (ZT): Enter the Zone Type response (or change it, if necessary).

Each zone must be assigned to a zone type, which defines the way in which the system responds to faults in that zone.

Enter the Zone Type code (or change it, if necessary). Zone types are listed below.

NOTE: If you enter 00, **Delete Zone ?** is displayed.

- | | | |
|------------------------------|-----------------------|---------------|
| 00 = Not used | 06 = 24-Hr Silent | 20 = Arm-STAY |
| 01 = Entry/Exit #1 | 07 = 24-Hr Audible | 21 = Arm-AWAY |
| 02 = Entry/Exit #2 | 08 = 24-Hr Aux | 22 = Disarm |
| 03 = Perimeter | 09 = Fire | 23 = No Alarm |
| 04 = Interior Follower | 10 = Interior w/Delay | Response |
| 05 = Trouble Day/Alarm Night | | |

Press [*] to continue.

10 Report Code		
1st 01	2nd 00	10

Report Code (RC): Enter the report code. This consists of 2 hexadecimal digits, each in turn consisting of 2 numerical digits.

For example, for a report code of "10," enter **01** and **00**. Refer to the **SYSTEM COMMUNICATION** section for more information about report codes and report code formats.

Press [*] to continue.



Note that report codes are defaulted to 10 for use with CID reporting.

10 INPUT TYPE	
RF TRANS	3

Enter Input Device type (In). *Used for Input Type entry.*

- 3 = RF (supervised RF transmitter)
- 4 = UR (unsupervised RF transmitter)
- 5 = Button-type RF transmitter (unsupervised)

Transmitter inputs entered as:

"RF" (Supervised RF) Type send periodic check-in signals, as well as fault, restore, and low-battery signals. The transmitter must remain within the receiver's range.

"UR" (Unsupervised RF) Type send all the signals that the "RF" type does, but the control does not supervise the check-in signals. The transmitter may, therefore, be carried off-premises.

"BR" (Unsupervised Button RF) Type only send fault signals. They do not send low-battery, restore, or check-in signals. The transmitter may be carried off-premises.

NOTE: For the built-in hardwired zones, the Input Device type is automatically displayed as HW and cannot be edited.

Press [*] to continue.

10	INPUT S/N:	L
	A022-4064	1

Note: The [A] and [B] keys may be used to move the cursor to the right (A) or left (B) within the serial number field, thus allowing you to correct any entry errors that may have been made.

Serial number Entry and Loop Number Entry.

Used only when enrolling wireless transmitters.

- a. Transmit an open and close sequence. If using a button-type transmitter, press and release the button;
OR
- b. Manually enter the 7-digit serial number printed on the label of the transmitter, using the alpha display keypad;
OR
- c. To copy the serial number previously enrolled (used when programming a transmitter with several input loops), simply press key [C].

The cursor then moves to the "L." You can edit the loop number, if necessary. When the loop number is acceptable, press [★].

10	INPUT S/N	L
	A022-4064	?

NOTE: If you use the [C] key to copy the previously enrolled serial number, the cursor moves to the Loop column (L) with the previous serial number displayed, and displays a question mark "?" for the loop number.

Enter the loop number and press [★]. Refer to the graphic of wireless devices on a following page in this section for the correct number of loops and loop identification numbers.

The system then checks for a duplicate serial/loop number combination.

If a **duplicate** serial/loop number combination is found, the keypad emits a single long beep, and displays the serial number along with a "?" for the loop number, allowing you to re-enter the correct loop number.

Press [★] to accept.

10	INPUT S/N	L
	A022-4064	1

If serial/loop number combination is not a duplicate in the system, a display showing the serial number and loop number entry appears.

Press [★] to continue.

5800 Series Transmitter Input Loop Identification

All of the transmitters illustrated on this page have one or more unique factory-assigned input (loop) ID codes. Each of the input loops requires its own programming zone (e.g., a 5804's four input loops require four programming zones).

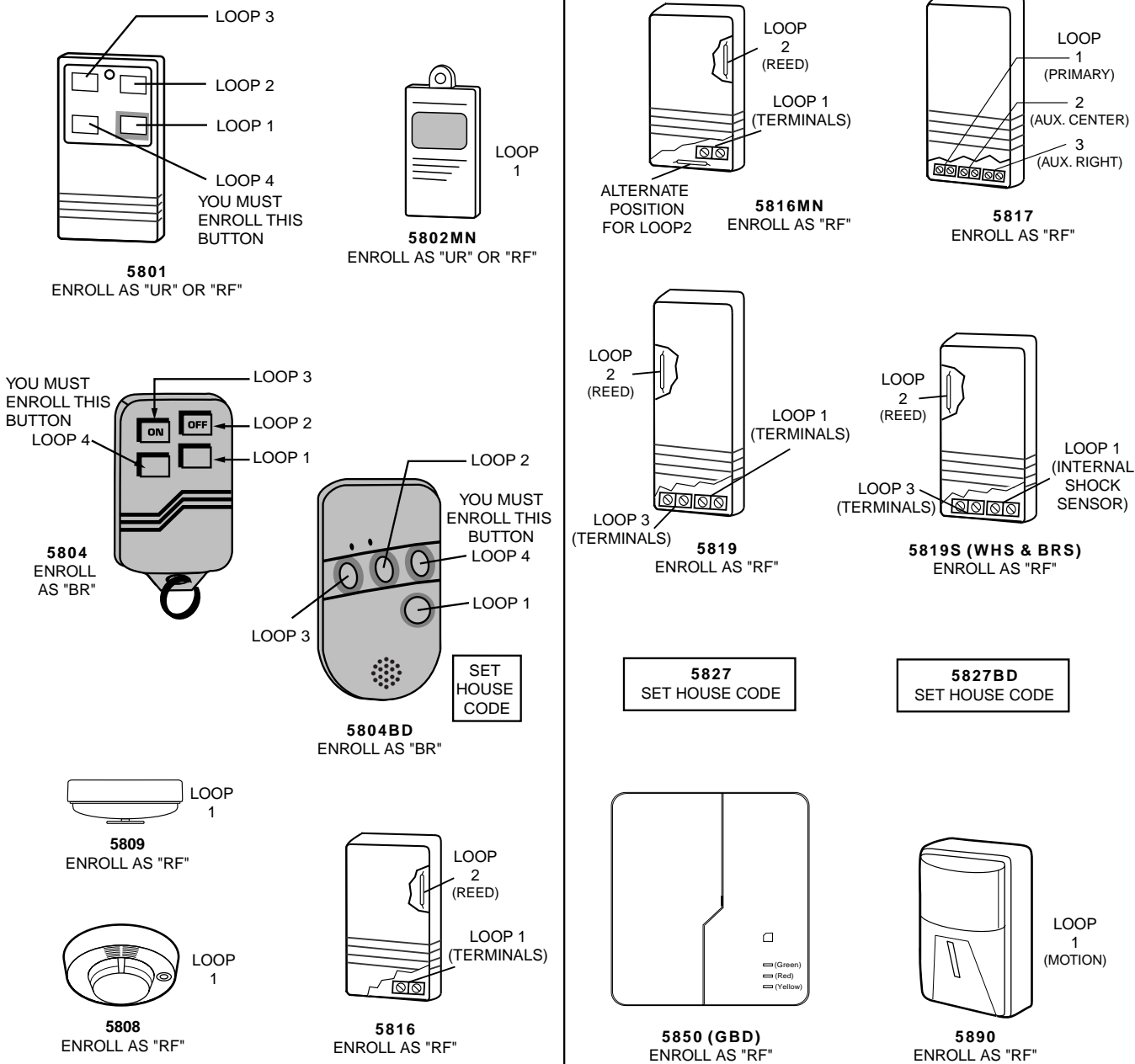

The 5802MN, 5802MN2, 5804, 5804BD, 5814, 5816TEMP, 5819, 5819S(WHS & BRS), 5827BD, and 5850 transmitters are not intended for use in UL installations.

XMIT TO CONFIRM PRESS * TO SKIP

Confirmation Option: *This prompt appears only if you answered **Yes** to the first prompt in this section.*

The system enters a confirmation mode so that the operation of the actual programmed input can be confirmed. Activate the loop input or button that corresponds to this zone.

We recommend that you confirm the programming of every transmitter before proceeding to the next zone.

If the serial/loop number combination transmitted **does not match** the serial number entered, a display similar to the one below appears. If the loop number does not match, it is also displayed.

Keyd	A022-4063	1
Rcvd	A022-4064	1

If so, activate the transmitter's loop input or button one or more times. If a match is still not obtained (i.e., summary display does not appear), press the [#] key twice and enter the correct loop input or, if correct, press the [#] key again and then enter the correct serial number.

Zn	ZT	RC	In:	L
10	03	10	RF:	1s

If the **serial number transmitted matches** the serial number entered, the keypad beeps 3 times and a summary display appears, showing that zone's programming. Note that an "s" indicates that a transmitter's serial number has been enrolled.

Press [*] to accept the zone information and display the **PROGRAM ALPHA?** prompt.

PROGRAM ALPHA?
0 = NO 1 = YES 0

If you want to program descriptors for zones now, enter **1** (Yes) and refer to the *ALPHA DESCRIPTOR PROGRAMMING* section for available descriptors.

ENTER ZN NUM.
(00 = QUIT) 11

If you entered **0** (No) above, the system returns you to the **ENTER ZN NUM.** prompt for the next zone.

When all zones have been programmed, enter **00** to quit.



When you have finished programming all zones, test each zone using the system's TEST mode. Do not use the Transmitter ID Sniffer Mode for checking wireless transmitting devices, as it only checks for transmission of one zone on a particular transmitter, **not** the zones assigned to each additional loop.

NOTE: Following the successful enrollment of each wireless device, remove **ONE** of the serial number labels from the device and affix it in the appropriate column on the ENROLLED TRANSMITTERS worksheet of the Programming Form. Then enter the other information (zone number, zone type, loop number, etc.) relevant to that device. This information will be useful if any troubleshooting is needed later on. The installer may want to consider leaving this worksheet at the site (in the panel cabinet).

*58 Expert Programming Mode Procedures

Enter the Program mode and follow the step-by-step instructions below.

NOTE: Before proceeding, you must program field *22 (RF System) as required.

SET TO CONFIRM?
0 = NO 1 = YES 0

Press *58. This display appears upon entry into this mode.

The default is **0** (No).

If you enter **1** (Yes), you are prompted to confirm each transmitter after entering the serial and loop numbers (see “XMIT TO CONFIRM” prompt on a following page). We recommend that you confirm the programming of **every** transmitter.

Zn ZT RC In: L
01 09 10 HW: 1

A summary screen appears, showing zone 01’s current programming or default values.

ZN ZT RC IN: L
10 - - -: -

Enter the first digit of the zone number to be programmed. In the example at the left, where zone 10 is to be programmed, the first digit **1** is entered, followed by the 2nd digit **0**. The display includes dashes, as shown at left. If zone 6 were to be programmed, you would press the [0] key, then the [6] key. You must always program zones using two digits.

Use the [D] key to enter wireless keys. When the [D] key is pressed, a special prompt is displayed that offers a series of default templates for wireless keys. Go to the paragraph on a following page titled “To Enter and Duplicate Wireless Keys” for the necessary procedure.

ZN ZT RC IN: L
10 00 10 RF: 1

A display with that zone’s current programming appears.

Press [*] to continue.

† If you enter HW (hardwired), the next screen is similar to the one above, except that HW is displayed under “In.”

Enter Zone Type (ZT), Report Code (RC), and Input Device Type (In) † sequentially, but not the Loop No. (L).

Use the [A] (Advance) and [B] (Back) keys on the keypad to move the cursor within the screen.

Use the [C] key to copy the previous zone's attributes.

Press [*] if the existing information is acceptable. If not, you can press the [#] key to back up without saving.

10 INPUT S/N: L
AXXX-XXXX 1

If you entered RF, BR, or UR as the Input Device, a prompt for Serial and Loop number is displayed, as shown at left.

10 INPUT S/N:	L
A022-4064	1

Note: The [A] and [B] keys may be used to move the cursor to the right (A) or left (B) within the serial number field, thus allowing you to correct any entry errors that may have been made.

Serial Number entry and Loop Number entry.

Used only when enrolling wireless transmitters.

- a. Transmit an open and close sequence. If you are using a button-type transmitter, press and release the button;
OR
- b. Manually enter the 7-digit serial number printed on the label of the transmitter, using the alpha display keypad;
OR
- c. To copy the serial number previously enrolled (used when programming a transmitter with several input loops), simply press key [C].

The cursor then moves to the "L." You can edit the loop number, if necessary. When the loop number is acceptable, press [★].

10 XMIT TO CONFIRM
PRESS ★ TO SKIP

The prompt to confirm appears. This prompt appears only if you answered "Yes" to the **SET TO CONFIRM?** prompt (the first prompt after entering this field ★58) previously. To confirm, activate the loop input or button that corresponds to this zone.

The system checks for a duplicate. If a duplicate exists, a long error beep sounds.

If a **duplicate** serial/loop number combination is found, the keypad emits a single long beep, and displays the serial number along with a "?" for the loop number, allowing you to re-enter the correct loop number.

Press [#] to back up and re-enter the serial and/or loop number.

If the serial/loop number combination transmitted **does not match** the serial and loop number entered, a display similar to the one below appears.

Keyd	A022-4063	1
Rcvd	A022-4064	1

If so, activate the transmitter's loop input or button one or more times.

If a match is still not obtained (i.e., summary display does not appear), press the [#] key twice and enter the correct loop input or, if correct, press [#] again and then enter the correct serial number.

Zn	ZT	RC	In:	L
11	00	10	RF:	-

If the serial number transmitted matches the serial number entered, the keypad beeps 3 times and advances to the Summary display of the next zone to be programmed.

Note that when editing, an "s" next to the loop number indicates that the transmitter's serial number has been enrolled.

NOTE: Following the successful enrollment of each wireless device, remove **ONE** of the serial number labels from the device and affix it in the appropriate column on the **ENROLLED TRANSMITTERS** worksheet of the Programming Form. Then enter the other information (zone number, zone type, loop number, etc.) relevant to that device. This information will be useful if any troubleshooting is needed later on. The installer may want to consider leaving this worksheet at the site (in the panel cabinet).

To Remove a Zone

To either temporarily or permanently remove a zone from the 5800 system:

1. Enter the programming mode: Key **Installer Code + 8 + 0** and press ***56**.

SET TO CONFIRM? 0 = NO 1 = YES 0

2. The display at left appears.
Enter 0 for No; 1 for Yes.

Enter Zn Num. (00 = Quit) 10

3. The display at left appears.
Enter zone number to be removed. Example: 10.
Press [*****] to continue.

Zn ZT RC In: L 10 03 10 RF: 1s

- This summary display at left appears.
Press [*****] to continue.

01 Zone Type Zone Disabled 00

4. Enter **00**. This sets the zone type to **Zone Disabled**.
Press [*****] to continue.

Delete Zone? 0 = No, 1 = Yes 0

5. The prompt at left asks if you want to delete the zone.

1 (Yes) permanently removes the zone from the system, while **0** (No) disables it but retains all data except the original zone type. You can then go back to this zone later and put back an active zone type to re-enable it.

A serial number that has been entered for a 5800 system will not be deleted if the zone is temporarily disabled by answering “No” to the prompt above.

If only the physical transmitter is to be removed or changed (that is, its serial number deleted, as when replacing a unit that has a non-removable battery), it can be done in ***56 Zone Programming Mode**, as indicated next.

To Delete a Transmitter Serial Number

The abbreviated procedure below can be used to delete and replace a transmitter serial number from a zone, using the ***56 Mode** (5800 system).

1. In the Programming mode, press ***56** to enter Zone Programming mode.

SET TO CONFIRM? 0 = NO 1 = YES 0

- This display appears upon entry into this mode.
The default is **0** (No).

If you enter **1** (Yes), you are prompted to confirm each transmitter after entering the serial and loop numbers. We recommend that you confirm the programming of **every** transmitter.

2. Enter the zone number, and press [*****] repeatedly until the cursor is under the RF Input Loop (L) position. This is the specific input (loop) or button on the transmitter that has been entered for that zone.
3. Enter **0** in the loop number field.

The serial number changes to all **0**'s. Note that the other programmed values for that zone are not deleted. This allows you to learn a new transmitter in its place.

10 INPUT S/N: L
A000-0000 0

Press [*****] to accept the **0** loop entry.

If you want to replace the serial number continue to step 4; otherwise, skip to step 7.
A display for the new transmitter number appears.

10 INPUT S/N:	L
Axxx-xxxx	1

4. Key the transmitter. The new transmitter serial number replaces the X's in the display.
5. The new summary display appears with a small "s" next to the loop number to indicate that the new transmitter serial number has been learned.

NOTE: Be sure to remove one of the serial number labels from the new transmitter and affix it over the old serial number label in the ENROLLED TRANSMITTERS worksheet in the Programming Form.

6. Press the [*] key repeatedly until "Enter Zone Number" prompt is displayed.
7. To exit, enter 00.
8. Press *99 to exit the Programming mode.

To Enter and Duplicate Wireless Keys

If you pressed the [D] key previously (from the beginning of the *56 mode) to enter and duplicate 5804 and/or 5804BD wireless keys, the following screens appear:

TEMPLATE ?	
1-6	1

1. Enter Template number 1-6 (next page).
1-3 = 5804 templates; 4-6 = 5804BD templates. See the defaults provided for each template in the chart that follows these procedures.

L	01	02	03	04
T	23	22	21	23

2. Select from templates. Press [*] to display template (1 shown selected). **NOTE:** If necessary, press [#] to back up and re-enter template number.
3. Press [#] if you want to return to zone attributes screen.

ENTER START ZONE	
00 = QUIT	22

Example of zone ↑
suggested by the
system. This indicates
that zones 22, 23, 24,
and 25 are available.

4. When you press [*], the selected template is displayed.
Top line of display represents loop numbers, bottom line represents zone type assigned for each zone.
5. Press [*] to accept template.
6. The system searches for the highest zone number available, subtracts the number of consecutive zones required for the device (four zones in the case of the 5804 and 5804BD), and displays the lowest zone number of the group.

If you want to start at a different zone, enter the zone desired and press [*].

If that zone number is displayed, the system has the required number of consecutive zones available, beginning with the zone you entered. If not, the system again displays a suggested zone that can be used.

If the required number of consecutive zones is not available at all, the system displays "00."

7. Press [*] to accept.
8. Enter the serial number of the wireless key or depress any button to transmit from the wireless key.
9. Press [*] to accept the serial number.

INPUT S/N	L
Axxx-xxxx	-

The system checks for a duplicate number.

If a duplicate exists, a long error beep will sound and the serial number reverts back to all "X"s allowing you to re-enter the serial number.

10. If necessary, press the [#] key to back up without saving, and re-enter the serial number.

If you are manually entering the serial number, use the [A] key to move forward within the screen, and the [B] key to move backward.

XMIT TO CONFIRM PRESS * TO SKIP

11. If you entered "Yes" at the **SET TO CONFIRM?** prompt previously (see first prompt following entry into the *56 or *58 Programming Mode), the display on the left appears. Confirm serial and loop numbers by activating the wireless key.

Keyd A022-4063 -
Rcvd A022-4064 3

If the serial number transmitted **does not match** the serial number entered, a display similar to the one at left appears.

If it doesn't match, press any button on the transmitter once again. If a match is not obtained, press the [#] key and then enter the correct serial number (steps 8 through 10 above).

If the serial number transmitted **matches** the serial number entered, the keypad beeps 3 times and returns you to step 6 above to enter the starting zone for the next wireless key.

After all wireless keys are programmed, enter 00 at the ENTER START ZONE prompt.

NOTE: Following the successful enrollment of each wireless device, remove **ONE** of the serial number labels from the device and affix it in the appropriate column on the ENROLLED TRANSMITTERS worksheet of the Programming Form. Then enter the other information (zone number, zone type, loop number, etc.) relevant to that device. This information will be useful if any troubleshooting is needed later on. The installer may want to consider leaving this worksheet at the site (in the panel cabinet).

Wireless Key Predefined Default Templates

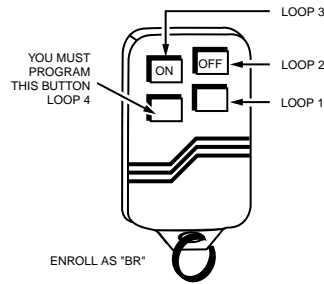

5804 Wireless Key Transmitter

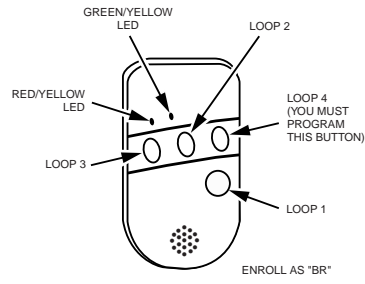

5804BD 2-Way Wireless Key Transmitter

For 5804			
TEMPLATE 1	Loop	Function	Zone Type
	1	No Response	23
	2	Disarm	22
	3	Arm AWAY	21
	4	No Response	23
TEMPLATE 2	Loop	Function	Zone Type
	1	No Response	23
	2	Disarm	22
	3	Arm AWAY	21
	4	Arm STAY	20
TEMPLATE 3	Loop	Function	Zone Type
	1	24-hour Panic	07
	2	Disarm	22
	3	Arm AWAY	21
	4	Arm STAY	20

For 5804BD			
TEMPLATE 4	Loop	Function	Zone Type
	1	No Response	23
	2	No Response	23
	3	Arm AWAY	21
	4	Disarm	22
TEMPLATE 5	Loop	Function	Zone Type
	1	No Response	23
	2	Arm STAY	20
	3	Arm AWAY	21
	4	Disarm	22
TEMPLATE 6	Loop	Function	Zone Type
	1	24-hour Panic	07
	2	Arm STAY	20
	3	Arm AWAY	21
	4	Disarm	22



The 5804 and 5804BD transmitters are not approved for use in UL installations.

Output Device Programming

(★80 Menu Mode)

In This Section

◆ Programming Options Defined

◆ Programming Output Devices

Programming Options Defined

The following definitions will help you understand the programming of output devices when using ★80 (this section) and ★81 (the Zone List section that follows). The options used to start and stop these devices are described below, followed by the actual screen prompts and available entries. We recommend that you first fill out the *Output Relays Worksheet for Fields ★80 and ★81* in the separate Programming Form prior to programming.



Relays and output devices are not recommended for life safety applications.

The letter(s) in parentheses after each function described below, such as (A) after ACTION, are those that appear in the various summary displays of programmed data during programming.

ACTION (A) The "ACTION" of the relay is how the relay will respond when it is activated by the "START" programming. You may want the relay to activate momentarily, to pulse on and off continuously, or to remain activated until some other event occurs to stop it. There are four different choices of actions:

- ACTIVATE for 2 SECONDS and then reset.
- ACTIVATE and REMAIN ACTIVATED until stopped by some other event.
- PULSE ON and OFF until stopped by some other event.
- NOT USED when the relay is not used.

START (STT) The "START" programming determines when and under what conditions the relay will be activated. The following START options are available:

1. **EVENT (EV)** is the condition (alarm, fault, trouble) that must occur to a zone or group of zones (zone list) in order to activate the relay. These conditions apply *only* when a zone list is used. The different choices for "EVENT" are listed below and in the "Programming Output Devices" paragraph that follows.
 - ALARM Relay action begins upon any alarm in an assigned zone in the zone list.
 - FAULT Relay action begins upon any opening or short in an assigned zone in the zone list.

- TROUBLE Relay action begins upon any trouble condition in an assigned zone in the zone list.
 - NOT USED Relay action is not dependent upon one of the above events.
2. **ZONE LIST (ZL)** is a group of zones to which the "EVENT" applies in order to activate a particular relay. Note that there are a total of 3 zone lists that can be programmed in field *81 mode; when the selected EVENT (Alarm, Fault or Trouble) occurs in **any** zone in the selected "Start" ZONE LIST (1, 2, or 3), activation of the selected relay will START.
 3. **ZONE TYPE/SYSTEM OPERATION (ZT)**. If a System Operation, such as "DISARMING" or "ANY FIRE ALARM," is to activate the relay, the appropriate choice would also be entered under the "ZONE TYPE" option. "ZONE TYPE" is used independently of the "EVENT/ZONE LIST" combination.

If a specific "ZONE TYPE" is chosen, any zone of that response type going into alarm, trouble, or fault will cause the relay to activate as selected in "ACTION." If the same "ZONE TYPE" is also chosen for the STOP programming, any zone of that type that *restores* will de-activate the relay.

If a "SYSTEM OPERATION" is chosen (e.g., End of Exit Time), that operation will cause the relay to activate as selected in "ACTION." The different choices for "ZONE TYPE" and "SYSTEM OPERATION" are listed in "Programming Output Devices" later in this section, and in the Programming Form.

STOP (STP): The "STOP" programming determines when and under what conditions the relay will be de-activated. The following options are available:

1. **RESTORE ZONE LIST (ZL)**. If a "ZONE LIST" is used as the "Stop" event, the relay will de-activate when **all** the zones in that list restore from a previous fault, trouble, or alarm condition. This will occur regardless of what is programmed to "START" the relay; therefore, a "RESTORE ZONE LIST" would normally only be used when a "ZONE LIST" is used to start the relay.
2. **ZONE TYPE/SYSTEM OPERATION (ZT)**. Instead of using a "RESTORE ZONE LIST," a specific zone (response) type or system operation action can be selected to de-activate the relay.

If a specific "ZONE TYPE" is chosen, any zone of that response type that restores from a previous alarm, trouble, or fault condition will cause the relay to de-activate.

If a "SYSTEM OPERATION" is chosen, that operation will cause the relay to de-activate. The different choices for "ZONE TYPE" and "SYSTEM OPERATION" are listed in "Programming Output Devices" later in this section, and in the Programming Form.



If relay outputs are used, two keypad entries available to the user are included among the system operation choices (34 and 35) that may be programmed. They can manually activate or de-activate the relay(s) for starting or stopping some action, such as turning lights on or off, etc.

These entries are: **Security Code + [#] + [7]**
and **Security Code + [#] + [8]**

NOTE: Whichever entry is used to start/stop the action cannot also be used to stop/start it. The opposite action must either be performed by the other keypad entry or by some other event or operation defined in the programming section.



If a relay is energized before a 4-wire smoke detector is reset, the relay will be stopped by the interruption of Aux. Power that resets the smoke detector. If this is not desired, the power to the relay unit should be supplied from another 12V power source (e.g., the same source that is powering external equipment through the relay contacts).

Programming Output Devices

1. With at least one 2-line alpha keypad (6139) connected to the keypad terminals on the control, power-up the system temporarily. If you previously connected the AC transformer to the control panel, you need only plug in the transformer (to 120VAC outlet) to power-up the system.

2. Enter the programming mode by keying the following on the alpha keypad:

INSTALLER code (4 1 1 1) + [8] + [0].



Field *25 OUTPUT RELAY MODULE must have been programmed for a 4204 module (enter "3").

3. **Press *80.** Note that this is an Interactive Menu Programming mode. It is used to program all output relays used in the system (4204 Relay modules). Refer to the Programming Worksheet in the separate PROGRAMMING FORM for *80 Interactive Mode.

Output Device Displays

Enter Relay No. (00 = Quit) 01
--

Upon pressing *80, this screen will appear. Enter the Relay Number 01, 02, 03, or 04 for a 4204 (or 00 to end these entries). Press the [*] key to continue.

The [*] key is used to accept an entry and advance to the next prompt. The [#] key is used to revert back to the last question to check or change an entry. Press [*] to go forward again.

02 A EV ZL ZT STT 0 0 0 00

This screen displays a summary of the current Relay START programming (for this example, relay 02 has been selected).

Press the [*] key to continue.

02 A EV ZL ZT STP - - 0 00

This screen displays a summary of the current Relay STOP programming.

Press the [*] key to continue.

02 Relay Action No Response 0

Enter the desired relay action as listed below.

0 = No response 2 = Close and Stay Closed

1 = Close for 2 seconds 3 = Continuous Pulse on & off (1 sec ON, 1 sec OFF)

Press the [*] key to continue.

02 Start Event Not Used 0

Enter the event to START the relay:

0 = Not used; 2 = Fault; 1 = Alarm; 3 = Trouble

A zone list must be used in conjunction with an event. If a zone type/system operation is to be used instead of an event, enter 0.

Press the [*] key to continue.

02 Start:	Zn List
No List	0

If a zone list will be used to START the relay action, enter the zone list number (to be programmed in field *81): 1, 2, or 3. If not used, enter 0. Press the [*] key to continue.

02 Start:	Zn Typ
Not Used	00

If a zone type or system operation will be used to START the relay action, enter the appropriate two-digit code (see table that follows). If not, enter 00. Press the [*] key to continue.

CHOICES FOR ZONE TYPES		
00 = Not Used	05 = Trouble Day/Alarm Night	08 = 24-Hr Aux
01 = Entry/Exit	06 = 24-Hr Silent	09 = Fire
03 = Perimeter	07 = 24-Hr Audible	10 = Interior w/Delay
04 = Interior Follower		
CHOICES FOR SYSTEM OPERATION		
20 = Arming-STAY	33 = Any Burglary Alarm	39 = Any Fire Alarm
21 = Arming-AWAY	34 = Code + # + 7 Key Entry	40 = Bypassing
22 = Disarming (Code + OFF)	35 = Code + # + 8 Key Entry	41 = AC Power Failure
31 = End of Exit Time	36 = At Bell Timeout**	42 = System Low Bat
32 = Start of Entry Time	38 = Chime	58 = Duress

**Or at Disarming, whichever occurs earlier.

02 Stop:	Zn List
No List	0

If a zone list will be used to STOP, or restore, the relay action, enter the zone list (ZL) number 1, 2, or 3 (to be programmed in *81 mode). If not used, enter 0.

Press the [*] key to continue.

02 Stop:	Zn Typ
Not Used	00

If a zone type or system operation will be used to STOP the relay action, enter the appropriate two digit code (see the "ZT" choices listed above). If not, enter 00. Press the [*] key to continue.

02	A	EV	ZL	ZT
STT	0	0	0	00

This screen again displays a summary of the current relay START programming.

Press the [*] key to continue.

02	A	EV	ZL	ZT
STP	-	-	0	00

This screen again displays a summary of the current relay STOP programming. Press the [*] key to continue.

The display then returns to the first screen so that the next relay number to be programmed can be entered, unless you enter [0][0] to end relay programming.



Previously entered data can be reviewed by pressing [#] [8] [0]. After the relay number is chosen, press [*] to go to the next screens. This is a review mode only, and data cannot be changed.

Zone Lists

(*81 Menu Mode)

In This Section

◆ About Zone List Menu Mode

◆ Zone List Displays

About Zone List Menu Mode

Zone List Menu mode is used to program zone lists for output devices (programmed in *80 Menu mode). Refer to the Programming Form worksheet (*81) that programs the Zone Lists for Output Devices.

To program the zone lists, press *81 while in Program mode.

Zone List Displays

Zone List No. (00 = Quit) 01

Enter the Zone List Number **01**, **02**, or **03** you want to program (or **00** to end these entries). Press [*****] to advance.

In the following displays, zone list 01 has been selected for programming.

01 Enter Zn Num. (00 = Quit) 00

Enter each zone number to add to the zone list by first entering the zone number, then ***** (for example, 01*, 02*, 03*). After all zones desired are entered, press **00** to advance.

IMPORTANT: Do not include fire zones in zone lists that are used to STOP relay actions.

01 Del Zn List? 0 = No 1 = Yes 0
--

To delete the zone list, enter **1** (Yes). All zones in the zone list are deleted automatically, and programming returns to the first screen.

To save the zone list, enter **0** (No) to advance.

01 Delete Zone? 0 = No 1 = Yes 0
--

To save the entire zone list, enter **0** (No). Programming returns to the first screen.

To delete a zone or zones in a zone list, enter **1** (Yes) to advance.

01 Zn to Delete? (00 = Quit) 00

Enter each zone to be deleted from the list, followed by *****. After all zones to be deleted are entered, enter **00** to return to the first screen so that another list can be programmed, if desired.



Any list may include any or all of the system's zone numbers **except** zone 08. A zone list can be assigned to more than one output relay.

Notes:

- Any list may include any or all of the system's zone numbers.
- A zone list can be assigned to more than one output relay.
- *If you only want to review what has been programmed previously, press #81. The review can be advanced by using the * key. When finished, press 00* to quit. No programmed values can be changed in this mode.*

When programming in *80 and *81 Interactive modes is completed, exit the programming mode by keying *99.

Alpha Descriptor Programming

(★82 Menu Mode)

In This Section

- ◆ About Alpha Descriptor Programming
- ◆ Zone Descriptors
- ◆ Programming Zone Descriptors
- ◆ Adding Custom Words

About Alpha Descriptor Programming

This Interactive mode section provides instructions for programming alpha descriptors and for adding custom words. This is recommended for systems using alpha keypads, and necessary if a 4285/4286 VIP Module is used. Alpha descriptors cannot be displayed on fixed-word keypads.

If you are using a 4285/4286 VIP Module, select from those words in the Alpha Vocabulary list (on a following page) shown in **boldface type**. *The VIP Module will not provide annunciation of the other words.*



If a VIP Module is added to an existing VISTA-10SE system, you must re-program the *alpha descriptors presently in the system*, selecting from those words shown in **boldface type** in the Alpha Vocabulary list. The VIP Module will not provide annunciation of any other words.

The ALPHA VOCABULARY LIST and CHARACTER CHART are on a following page.

Zone Descriptors

The alpha keypad used with the VISTA-10SE can have a user-friendly English-language descriptor/location of all protection zones, keypad panics, and RF receiver supervision faults programmed into the system. Each descriptor can be composed of a combination of words (up to a maximum of 3) selected from a vocabulary of words stored in memory (see the list on a following page). In addition, up to 5 installer-defined words can be added to those already in memory. Thus, when an alarm or trouble occurs in a zone, an appropriate descriptor for that zone's location will be displayed at the keypad.

NOTE: Alpha descriptor entry can be done locally at the alpha keypad or remotely using downloading software. The alpha keypad procedure is described below.

Programming Zone Descriptors

You can enter the descriptor when the zone is being defined in field *56, but we recommend you do it using this ★82 Menu mode.

To program zone descriptors, enter the 3-digit reference number for the desired word(s). The 3-digit number for each word is provided in the Alpha Vocabulary List on a following page.

1. With the system powered up, enter the Programming mode by keying:
Installer Code (4 1 1 1) + 8 + 0. The following display will appear:

Installer Code	20
----------------	----

Program Alpha ?
0 = No, 1 = Yes 0

Custom Words ?
0 = No, 1 = Yes 0

2. **Enter *82.** The “Program Alpha ?” prompt appears.
If you press 0 (No), proceed to step 4.

3. **By pressing 1 (Yes) in step 2 above:**
The “Custom Words ?” prompt appears. Proceed to the six steps for Adding Custom Words later in this section.

4. **By pressing 0 (No) in step 2:** The system then automatically displays the default descriptor for zone 01.

Default Descriptor ↓
★ ZN 01 ZONE 01

If a descriptor was not entered previously for zone 01, the default descriptor for zone 01 will be displayed.

Note that no entries can be made. Entries can be made only when the display contains a flashing cursor, which signifies the “entry mode.”

Flashing Cursor (system is ready for entry of word).

↓
★ ZN 01

5. To delete or change the default descriptor for zone 1, **press [*] plus the same zone number (01).** This will clear that descriptor and gain access to the entry mode with flashing cursor, allowing changes to be made.

NOTE: If you do not wish to change the existing descriptor for zone 01, enter [*] plus the next zone number for which you wish to enter (or check) a descriptor. A summary display for that zone will appear. You must then press [*] plus the same zone number again to gain access to the entry mode (flashing cursor) for that zone.

Flashing Cursor ↓

★ ZN 01 ACK

6. **Press [#] plus a 3-digit number** for the first word from the ALPHA VOCABULARY LIST on a following page. *Example:* The descriptor that we wish to enter for zone 01 is BACK DOOR. From the LIST, BACK = 013.

Therefore, we enter # **0 1 3**.

NOTE: If you accidentally enter the wrong word, simply press [#] plus the correct 3-digit number for the word you want.

★ ZN 01 BACK

7. **Press [6] to accept the selected word and continue.**

NOTE: If **this** is the only word you are using for the descriptor, press [8] instead of [6] to save that word in memory, and then go to step 11.

↑ Flashing Cursor if [6] is pressed (system is ready for next word).

★ ZN 01 BACK
 OOR

8. **Enter the 3-digit number for the next word.** In our example, the word is DOOR, whose number is “057.”

Enter # **0 5 7**. This display will appear:

↑ Flashing Cursor

```

* ZN 01  BACK
DOOR  A
    
```



Flashing Cursor if “6” is pressed (system is ready for next word).

```

* ZN 01 BACK
DOOR
    
```

```

Alpha Pgm
                82
    
```

9. Press [6] to **accept** the selected word.

NOTE: If these are the only words you are using for the descriptor, press [8] instead of [6] to save them in memory.

10. The two words in our example have now been entered. Note, however, that up to three words may be entered (provided the number of characters will fit on the screen). **Press [8] to save all words in memory.**

The “A” with the flashing cursor over it will disappear, indicating that the word(s) are stored in memory for that zone, as shown in the display at the left.

11. To enter a descriptor for the next zone, press [*] plus the desired zone number (e.g., *02. The summary display following step 4 previously appears. Now repeat steps 6 through 10 for the descriptor for the next zone.

12. To exit the Alpha Descriptor mode, enter *00 at the summary display.

This prompt will be displayed.

13. Enter *99 to exit the Programming mode.

Adding Custom Words (will not be announced by the 4285/4286 VIP Module)

You can add up to five installer-defined words to the built-in vocabulary. Each of the five "words" can actually consist of a "word string" of one or more words, but no more than a total of *ten* characters (*including spaces*) can be used for each word or word string.



Custom words must begin with an *alphabetic* character. If a number or symbol is used as the first character, the word will **not** be saved.

1. Perform steps 1, 2, and 3 of **Programming Zone Descriptors** on a previous page.

Select CUSTOM WORD mode and enter “1” (Yes) when the prompt **CUSTOM WORD ?** is displayed.

Custom words are found as numbers 250-254 on the Alpha Vocabulary List.

2. Enter the number (1–5) of the custom word or word string to be created (for example, if you are creating the *first* custom word or word-string, enter 1; for the *second custom word*, enter 2, etc.). A blinking cursor will now appear at the beginning of the second line.

3. **To enter the custom word' characters, refer to the CHARACTER (ASCII) CHART of letters, numbers, and symbols on a following page:**

Press the [#] key, followed by the two-digit entry for the first letter you would like to display (for example, press #65 for "A," press #84 for "T," etc.).

4. When you have displayed the desired character, press [6] to select it. The cursor will then move one position to the right, ready for the next character.

5. Repeat steps 3 and 4 to create the desired word(s). Note that the [4] key can be used to move the cursor to the left. Use the [6] key to make a space between characters. **Remember, no word or word-string can exceed 10 characters including spaces.**
6. Press the [8] key to save the custom word(s) and return to the "**CUSTOM WORD ?**" display. The custom word(s) you entered will automatically be added to the built-in vocabulary.

Repeat steps 2–5 for other custom words to be entered. To change a custom word, just overwrite it. If no more custom words are to be entered now, press [0] to return to the Program Alpha? prompt. Then press 0 (No). The Alpha Pgm-82 prompt appears. To advance to the next field, press * and the desired field.

ALPHA VOCABULARY LIST

(For Entering Zone Descriptors)

NOTE: Some rarely used words appearing in previously published lists have been deleted from the list below. Use only this list for selecting zone descriptors.

000 (Word Space)	055 DISPLAY	K	R	• 207 UPSTAIRS
• 001 AIR	• 057 DOOR	• 105 KITCHEN	155 RADIO	• 208 UTILITY
• 002 ALARM	• 059 DOWN	L	• 156 REAR	V
004 ALLEY	• 060 DOWNSTAIRS	• 106 LAUNDRY	157 RECREATION	209 VALVE
005 AMBUSH	061 DRAWER	• 107 LEFT	159 REFRIGERATION	210 VAULT
• 006 AREA	• 062 DRIVEWAY	108 LEVEL	160 RF	212 VOLTAGE
• 007 APARTMENT	• 064 DUCT	• 109 LIBRARY	• 161 RIGHT	W
• 009 ATTIC	E	• 110 LIGHT	• 162 ROOM	213 WALL
010 AUDIO	• 065 EAST	111 LINE	163 ROOF	214 WAREHOUSE
B	066 ELECTRIC	• 113 LIVING	S	• 216 WEST
• 012 BABY	067 EMERGENCY	• 114 LOADING	164 SAFE	• 217 WINDOW
• 013 BACK	068 ENTRY	115 LOCK	165 SCREEN	• 219 WING
• 014 BAR	• 069 EQUIPMENT	116 LOOP	166 SENSOR	220 WIRELESS
• 016 BASEMENT	• 071 EXIT	117 LOW	• 167 SERVICE	X
• 017 BATHROOM	072 EXTERIOR	• 118 LOWER	• 168 SHED	222 XMITTER
• 018 BED	F	M	169 SHOCK	Y
• 019 BEDROOM	• 073 FACTORY	• 119 MACHINE	• 170 SHOP	223 YARD
020 BELL	075 FAMILY	121 MAIDS	171 SHORT	Z
• 021 BLOWER	• 076 FATHERS	122 MAIN	• 173 SIDE	224 ZONE (No.)
• 022 BOILER	• 077 FENCE	• 123 MASTER	174 SKYLIGHT	• 225 ZONE
023 BOTTOM	• 079 FIRE	• 125 MEDICAL	175 SLIDING	• 226 0
025 BREAK	• 080 FLOOR	126 MEDICINE	• 176 SMOKE	• 227 1
• 026 BUILDING	081 FLOW	128 MONEY	• 178 SONS	• 228 1ST
C	082 FOIL	129 MONITOR	• 179 SOUTH	• 229 2
028 CABINET	• 083 FOYER	• 130 MOTHERS	180 SPRINKLER	• 230 2ND
• 029 CALL	084 FREEZER	• 131 MOTION	• 182 STATION	• 231 3
030 CAMERA	• 085 FRONT	132 MOTOR	184 STORE	• 232 3RD
031 CAR	G	N	• 185 STORAGE	• 233 4
033 CASH	• 089 GARAGE	• 134 NORTH	186 STORY	• 234 4TH
034 CCTV	• 090 GAS	135 NURSERY	190 SUPERVISED	• 235 5
035 CEILING	091 GATE	• 136 OFFICE	191 SUPERVISION	• 236 5TH
036 CELLAR	• 092 GLASS	• 138 OPEN	192 SWIMMING	• 237 6
• 037 CENTRAL	093 GUEST	• 139 OPENING	193 SWITCH	• 238 6TH
038 CIRCUIT	094 GUN	• 140 OUTSIDE	T	• 239 7
• 040 CLOSED	• 095 HALL	142 OVERHEAD	194 TAMPER	• 240 7TH
• 046 COMPUTER	• 096 HEAT	P	196 TELCO	• 241 8
047 CONTACT	098 HOLDUP	143 PAINTING	197 TELEPHONE	• 242 8TH
D	99 HOUSE	• 144 PANIC	• 199 TEMPERATURE	• 243 9
• 048 DAUGHTERS	I	145 PASSIVE	• 201 TOOL	• 244 9TH
049 DELAYED	• 100 INFRARED	• 146 PATIO	202 TRANSMITTER	
• 050 DEN	• 101 INSIDE	147 PERIMETER	U	250 Custom Word #1
051 DESK	102 INTERIOR	• 148 PHONE	• 205 UP	251 Custom Word #2
• 052 DETECTOR	103 INTRUSION	150 POINT	• 206 UPPER	252 Custom Word #3
• 053 DINING	J	151 POLICE		253 Custom Word #4
054 DISCRIMINATOR	104 JEWELRY	152 POOL		254 Custom Word #5
		• 153 POWER		

NOTE: Bulleted (•) words in **boldface type** are those that are also available for use by the 4285/4286 VIP (Phone) Modules. If you are using a VIP Module, and words other than these are selected for alpha descriptors, the module will not provide announcement of those words.

CHARACTER (ASCII) CHART

(For Adding Custom Words)

32 (space)	40 (49 1	58 :	67 C	76 L	85 U
33 !	41)	50 2	59 ;	68 D	77 M	86 V
34 "	42 *	51 3	60 <	69 E	78 N	87 W
35 #	43 +	52 4	61 =	70 F	79 O	88 X
36 \$	44 ,	53 5	62 >	71 G	80 P	89 Y
37 %	45 -	54 6	63 ?	72 H	81 Q	90 Z
38 &	46 .	55 7	64 @	73 I	82 R	
39 '	47 /	56 8	65 A	74 J	83 S	
40 (48 0	57 9	66 B	75 K	84 T	

Remote Programming and Control (Downloading)

In This Section

◆ *About Remote Programming*

◆ *Equipment Required*

About Remote Programming

The VISTA-10SE can be remotely programmed from an IBM compatible Personal Computer (PC) a modem, and ADEMCO's *Compass* Windows downloading software.

Programming the control from a remote location is protected against compromise by someone attempting to defeat the system, using multi-levels of security protection:

1. **Security Code Handshake:** An 8-digit download ID code must be matched between the control and the downloader.
2. **Site-Initiated Remote Programming:** Telco Hand-off feature allows the technician at the site to call the downloading facility from the control panel phone line, initiate a site download (Installer or Master Code + # + 1), and the control will immediately be on-line with the modem at the downloading facility. Also, if a local computer has a modem, the telephone line terminals of the control can be connected to the modem, and a direct download connection can be established with the new downloader program.
3. **Station-Initiated Remote Programming:** The operator calls the site from your office to initiate the download call. The control hangs up and then calls back the PC via the pre-programmed telephone number. The unit can then be uploaded, downloaded, or controlled from your office.

The control can also be set for no callback by the downloader.

4. **Data Encryption:** Data passed between the PC and the control is encrypted for security so that it is very difficult for a foreign device tapped into the phone line to take over communication and substitute system-compromising information.

UL

Downloading is not permissible for UL installations unless an installer is present at the installation site.

Equipment Required

At the premises:

VISTA-10SE and keypad.

At the installer's office/home:

An IBM PC-compatible computer.

Either a SMARTMODEM 1200 (Level 1.2 or higher external or Level 1.1 or higher [with 4 position DIP switch] internal style), *or* an Optima 24 Plus FAX96 Modem.

ADEMCO's *Compass* Windows downloading software.

Appropriate interconnecting cables.

Remote Programming Information

The downloading system can perform many functions when in communication with the control unit. Besides uploading and downloading, the status of the system can be observed and various commands can be initiated, as follows:

Arm the system in the AWAY mode; disarm the system.

Bypass a zone.

Shut down communication (dialer) functions (e.g., for non-payment of monitoring fees in an owned system).

System Communication

In This Section

- ◆ *Panel Communication with Central Station*
- ◆ *System Communication Programming*
- ◆ *Report Code Formats*

Panel Communication with Central Station

This section provides an explanation of formats this system accommodates for reporting alarms and other system conditions to the central station. The process of a successful transmission consists of both the method of communication between the control panel and the central station receiver; and the actual way the information is sent and displayed at the central station.

Report Code Formats

When the panel calls the central station receiver, it waits to hear a **“handshake”** frequency from the receiver to confirm that the receiver is on-line and ready to receive its message. Once the panel hears the handshake it is programmed to listen for, it sends its message. The panel then waits for a **“kissoff”** frequency from the receiver acknowledging that the message was received and understood.

If the handshake frequency is not given or is not understood by the panel, the panel will not send its message. Once the handshake frequency is received and understood by the panel, the panel will send its message. If there is an error in the transmission (the receiver does not receive a “valid” message), the kissoff frequency will not be given by the central station receiver.

The panel will make a total of eight attempts to the primary telephone number and eight attempts to the secondary telephone number (if programmed) to get a valid message through. If the panel is not successful after its numerous attempts, the keypad will display “Communication Failure” (on an alpha keypad) or “FC” (on a fixed-word keypad).

The following chart defines the three sets of (handshake/kissoff) frequencies that the panel supports and the different formats that can be sent for each.

FORMAT TIME	HANDSHAKE	TRANSMITS DATA	KISSOFF	TRANSMIT TIME
Low Speed 3+1 4+1 4+2	1400Hz	1900Hz (10PPS)	1400Hz	Under 15 secs. (Standard report)
Sescoa/Rad 3+1 4+1 4+2	2300Hz	1800Hz (20PPS)	2300Hz	Under 10 secs. (Standard report)
4+2 Express	1400–2300Hz	DTMF (10 cps)	1400Hz	Under 3 secs.
Contact ID	1400–2300Hz	DTMF (10 cps)	1400Hz	Under 3 secs.

The following describes each format in greater detail.

3+1 and 4+1 Standard Formats	Comprise a 3- (or 4-) digit subscriber number and a single-digit report code (e.g., Alarm, Trouble, Restore, Open, Close, etc.).
3+1 and 4+1 Expanded Formats	Comprise a 3- (or 4-) digit subscriber number, and a two-digit report code. The first digit is displayed on the first line. On the second line, the first digit is repeated 3 (or 4) times and is followed by the second digit. This is the "expanded" digit.
4+2 Format	Comprises a 4-digit subscriber number and 2-digit report code.
ADEMCO Contact ID Reporting Format	Comprises a 4-digit subscriber number, 1-digit event qualifier ("new" or "restore"), 3-digit event code, and 3-digit zone number, user number, or system status number (see the following page).

ADEMCO Contact ID Reporting takes the following format:

CCCC Q EEE GG ZZZ

where: CCCC = Customer (subscriber) ID

Q = Event qualifier, where:

E = new event , and R = restore

EEE = Event code (3 hexadecimal digits)

NOTE: For a complete list of event codes, refer to the central office receiver manual.

GG = Always 00.

ZZZ = Zone/contact ID number reporting the alarm, or user number for open/close reports.
System status messages (AC Loss, Walk Test, etc.) contain zeroes in the ZZZ location.

TABLE OF CONTACT ID EVENT CODES

Code	Definition
110	Fire Alarm
121	Duress
122	Alarm, 24-hour Silent
123	Alarm, 24-hour Audible Panic
131	Alarm, Perimeter, Burg.
132	Alarm, Interior, Burg.
134	Alarm, Entry/Exit, Burg.
135	Alarm, Day/Night, Burg.
150	Alarm, 24-Hour Auxiliary
301	AC Power
302	Low System Battery/Battery Test Fail
321	Bell/Siren Trouble
333	Expansion Module Fail
344	Trouble, RF Jam Detect
353	Long-Range Radio Trouble

Code	Definition
373	Fire Loop Trouble
374	Exit Error Alarm
380	Trouble (Global)
383	RF Sensor Tamper
384	RF Sensor Low Battery
401	O/C by User
406	Cancel by User
407	Remote Arm/Disarm (Download)
408	Quick Arm AWAY/MAX
441	Armed STAY/INSTANT, Quick Arm STAY/INSTANT
570	Bypass
601	Test, Manually Triggered
602	Periodic Test
606	AAV to follow

System Communication Programming

Programming information of those data fields that affect communications between the control and the central station is included in the sections *DATA FIELD DESCRIPTIONS* and *ZONE PROGRAMMING* (*56 and *58 menu modes).

System Operation

In This Section

- ◆ Security Codes
- ◆ Keypad Functions
- ◆ 4285/4286 VIP Module
- ◆ Exit Error Alarm Displays
- ◆ Trouble Conditions

Security Codes

Installer Code

The installer programs the 4-digit Installer Code initially as part of the programming procedure. The factory default Installer Code is "4-1-1-1", but may be changed in field *20.

NOTE: The Installer Code is defined as User 1.

The Installer Code is the only code that can allow re-entry into Programming mode. In normal operation mode, only the Master code can be used to enter the User codes (refer to *Assigning the Master Code*).

See the *MECHANICS OF PROGRAMMING* section for details on exiting the Programming mode via *98 or *99.

Assigning the Master Code

In normal operation mode, assign the 4-digit Master Code as follows:

Installer Code + 8 + 2 + 4-digit Master Code

NOTE: The Master Code is defined as User 2.

Changing the Master Code

In normal operation mode, the Master Code can be changed by entering:

Master Code + 8 + 2 + New Master Code + New Master Code again

User Codes

In normal operation mode, the Master Security Code can be used to assign up to 4 secondary 4-digit security codes. It can also be used to remove secondary codes from the system (individually).

To assign (or change) a Secondary security code, enter (*via keypad*):

Master Code + [CODE] key + User No. (3–6) + desired 4-digit Secondary Code

The system will emit a single beep when each secondary code has been successfully entered.

To delete a Secondary security code, enter (*via keypad*):

Master Code + [CODE] key + User No. (3–6)

NOTES:

- All Master and Secondary security codes permit access to the system for arming, disarming, etc.
- If a Secondary code is inadvertently repeated for different users, the lower user number will take priority.
- Opening and closing reports are sent for the Master Code as No. 02, with the appropriate subscriber number. Secondary user codes are sent as Nos. 3 through 6 respectively, with the appropriate subscriber number.

Duress Code

This feature is intended for use when you are forced to disarm or arm the system under threat. When used, the system will act normally, but can silently notify the central station of your situation, if that service has been provided.

Important: This code is useful only when the system is connected to a central station.

The Duress code may be any 4-digit code assigned to User Number 8.

To program a Duress code

1. Enter Master Code.
2. Press the CODE [8] key.
3. Press the [8] key again (8 = Duress Code User No.).
4. Enter the desired 4-digit Duress Code. The keypad will beep once.

NOTE: The Duress Code must differ from the Master Code or any other User's Code.

To change the Duress Code:

Repeat above steps 1, 2, and 3, and then step 4 with the new Duress Code.

To delete the Duress Code

Perform steps 1, 2, and 3, and then stop. When the keypad beeps once, it signifies that the code has been deleted.

Keypad Functions

Note that if you enabled QUICK ARM (field *21), you can press the [#] key instead of entering the security code, for any of the arming procedures (AWAY, STAY, INSTANT, or MAXIMUM). The security code is ***always*** required, however, when disarming the system.

NOTE: The "Quick Arm" feature will function only if the Master Code has been programmed (see *Assigning the Master Code* on a previous page).

The keypad displays zone descriptors and allows the user to perform such system functions as arming and disarming the system, and bypassing zones. Zone and system conditions (alarm, trouble, bypass) are displayed in the display window.

When an alarm occurs, keypad sounding and external sounding occur, and the zone(s) in alarm are displayed on the keypad. Pressing any key will silence the keypad sounder for 10 seconds. Disarming the system will silence both keypad and external sounders. When the system is disarmed, any zones that were in an alarm condition during the armed period will be displayed (memory of alarm). To clear this display, simply repeat the disarm sequence (enter the security code and press the [OFF] key) *again*.

The keypads also feature chime annunciation, and 3 panic key pairs, or individual panic keys (depending on keypad type – see *Panic Keys* on next page), for silent, audible, fire, or personal emergency alarms. These keys can notify the central station of an alarm condition, if that service is connected.

Arming Functions

The following is a brief list of system commands. For detailed information concerning system functions, refer to the User's Manual.

Disarmed, Not Ready..... Before arming, the system must be in the READY condition (all zones must be intact). If the "NOT READY" message appears, press the READY [*] key to display faulted zones.

Arming AWAY..... Enter code + AWAY [2].

Arming STAY..... Enter code + STAY [3].

- Arming INSTANT** Enter code + INSTANT [7].
- Arming MAXIMUM**..... Enter code + MAXIMUM [4].
- Quick Arming** Simply press [#] key in place of code, then press
(if enabled) AWAY, STAY, INSTANT, or MAXIMUM to arm system as desired. Note that the [#] key cannot be used in place of code when disarming the system.
- Disarming**..... Enter code + OFF [1].
- Bypassing Zones** Enter code + BYPASS [6] + zone number(s).
- Forced (Quick) Bypass** To automatically bypass all faulted zones, use
(if enabled) the "Quick Bypass" method:
Enter code + BYPASS, then wait for all open zones to be displayed. Arm when display indicates "Bypass" and "Ready to Arm".
- Chime Mode** Enter code + CHIME [9].
To turn chime off, enter code + CHIME again.

SUMMARY OF ARMING MODES

Arming Mode	Features for Each Arming Mode			
	Exit Delay	Entry Delay	Perimeter Armed	Interior Armed
AWAY	Yes	Yes	Yes	Yes
STAY	Yes	Yes	Yes	No
INSTANT	Yes	No	Yes	No
MAXIMUM	Yes	No	Yes	Yes

Panic Keys

There are three individual panic keys or, on some keypads, panic key pairs. If programmed, they can be used to manually initiate alarms and send a report to the central station.

Each key (or key pair) can be individually programmed for 24-hour Silent, Audible, Personal, or Fire Emergency responses. The panic function is activated when both keys of the appropriate key pair are pressed at the same time, or the appropriate lettered key is pressed for at least 2 seconds.

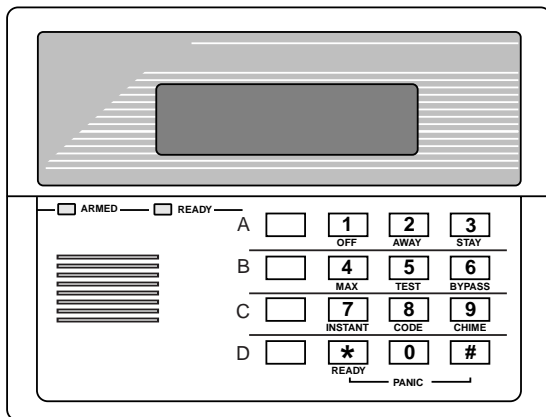

Shown above is a typical alpha keypad with individual Panic keys (shown lettered).

The panic functions are identified by the system as follows:

Keys	Displayed as Zone
[A], or [1] & [*]	95
[B], or [*] & [#]	7
[C], or [3] & [#]	96

Notes:

- Keys [A], [B], [C] are not on all keypads.
- Key [D], if present, is not active here.

Important: For the Silent Panic functions to be of practical value, the system must be connected to a central station.

4285/4286 VIP Module (if used)

Refer to the separate instructions supplied with the VIP Module for information concerning its operating procedures.

Relay Outputs (if used)

If relay outputs are used, two keypad entries available to the user are included among the system operation choices (34 and 35) that may be programmed (see the *OUTPUT DEVICE PROGRAMMING* section). They can manually activate or de-activate the relay(s) for starting or stopping some action, such as turning lights on or off, etc.

These keypad entries are: **Security Code + [#] + [7]**

and **Security Code + [#] + [8]**

NOTE: The keypad entry that is used to Start/Stop the action, cannot also be used to Stop/Start it. The opposite action must either be performed by the other keypad entry or by some other event or operation offered in the *OUTPUT DEVICE PROGRAMMING* section.

Exit Error Alarm Displays (if programmed)

- A display of "CANCELED ALARM" or "CA" and a zone indication will appear if an exit or interior zone contained a fault during closing at the time the exit delay ended (e.g., exit door left open), *but the system was disarmed during the entry delay time*. The alarm sounder and keypad sound continuously, but stop when the system is disarmed. No message will be transmitted to the central station.
- A display of "EXIT ALARM" or "EA" and a zone indication will appear if an exit or interior zone contained a fault during closing at the time the exit delay ended, *but the system was NOT disarmed during the entry delay time*. The alarm sounder and keypad sound continuously until the system is disarmed (or timeout occurs). An "exit alarm" message is sent to the central station.
- The "EXIT ALARM" display, etc. will also result if an alarm from an exit or interior zone occurs within two minutes after the end of an exit delay.

In any of the previous cases, use a second OFF sequence (**CODE** plus [OFF] key) to clear the display.

Trouble Conditions

The word **CHECK** on the keypad's display, accompanied by a rapid "beeping" at the keypad, indicates that there is a trouble condition in the system. The audible warning sound can be silenced by pressing any key. Instruct users to call for service immediately upon seeing any of the following messages:

CHECK and BATTERY Displays

- A display of **CHECK** and one or more zone numbers indicates that a problem exists with the displayed zone(s) and requires attention.
- A display of **CHECK** and **09** indicates that communication between control and a zone expander or wireless receiver is interrupted. Check the wiring and DIP switch settings on the units. Also see **CHECK 70** and **CHECK 90** on a following page under *Other Displays*.
- **If there are wireless sensors in the system**, the CHECK condition may also be caused by some change in the environment that prevents the receiver from receiving signals from a particular sensor.

- A display of **BAT** (on fixed-word keypads) or **SYSTEM LO BAT** (on alpha keypads) with **no** zone number indicates that the system's main standby battery is weak.
- A display of **"BAT"** (on fixed-word keypads) or **"LO BAT"** (on alpha keypads) with a zone number and a once per minute **"beeping" at the keypad** indicates that a low-battery condition exists in the wireless sensor displayed (zone "00" indicates a wireless keypad). If the battery is not replaced within 30 days, a **CHECK** display may occur.
- **Bell Failure (CHECK 70)** Wiring loop to external sounder is either open or shorted.
- **RCVR Jam (CHECK 90)** RF jam detected.

NOTE: Some wireless sensors contain a nonreplaceable long-life battery that requires replacement of the entire unit at the end of battery life (e.g., 5802, 5802CP).

Power Failure

- If there is **no** keypad display at all, and the **POWER** indicator (if present) is not lit, operating power for the system has stopped and the system is inoperative.

NOTE: The control panel will power-up in its previous state (armed or disarmed) after a complete power failure, but will not retain any memory of bypasses.

- If the message **AC LOSS** (on alpha keypads) or **NO AC** (on fixed-word keypads) is displayed, and the **POWER** indicator (if present) is off, the keypad is operating on battery power only.

NOTE: There is a random delay of up to 30 minutes before the system will report an AC failure to the central station. The keypad response is about 6 seconds. The Restore Report has a random delay of up to 30 minutes (if the AC Failure Report was sent).

- If the battery standby capacity is used up during a prolonged AC power outage, the control's auxiliary power will shut down to minimize deep discharge of the battery.

Other Displays (fixed-word displays are in parentheses)

Busy-Standby (dI). If this remains displayed for more than 1 minute, the system is disabled.

Modem Comm (CC) The system is in communication with the central station for change of function or status verification.

Comm. Failure (FC) A communication failure has occurred.

Open Circuit (OC) The keypad is not receiving signals from the control and sees an open circuit.

Long Rng Trbl (bF) Backup LRR communication failure.

Testing the System

In This Section

◆ Test Procedures

◆ Go/No Go Test

◆ Transmitter Sniffer Mode

Test Procedures

After installation is completed, the system should be carefully tested, as follows:

1. With the system in the disarmed state, check that all zones are intact. If a **NOT READY** message is displayed, press the [*] key to display the faulted zone(s). Restore faulted zone(s) if necessary, so that the **READY** message is displayed.
2. Enter the security code and press the **TEST** key.
The external sounder will sound for 1 second. If the backup battery is discharged or missing, the sounder may not turn on and a LOW BATTERY report will be transmitted with a TEST report.
Note that the keypad will beep once every 40 seconds as a reminder that the system is in the Test mode.
3. Fault and restore every sensor individually to assure that it is being monitored by the system. Each time a protection zone is faulted, the keypad will sound 3 beeps, and the identification of each faulted protection zone should appear on the keypad display.
NOTE: For 5800 wireless systems, triggering a zone set to Arm-AWAY, Arm-STAY, or Disarm will take the system out of the TEST mode and cause that action.
4. Walk in front of any interior motion detectors (if used) and listen for the required sound as movement is detected. The identification of the detector should appear on the display when it is activated.
NOTE: Wireless motion detectors (passive infrared units) will send signals out only if they have been inactive for 3 minutes.
5. Follow the manufacturer's instructions to test all smoke detectors, to ensure that all are functioning properly. The identification of each detector should appear on the display when each is activated.
6. Turn off the test mode by entering the security code and pressing the [OFF] key.
Alarm messages will be sent to the central station during the following tests. Notify CS personnel *in advance* that tests will be in progress.
7. Arm the system (STAY) and fault one or more perimeter zones. After 15 seconds, silence alarm sounder(s) by entering the security code and pressing [OFF].
Arm the system AWAY, and check the Entry/Exit zones for the programmed exit and entry delays.
8. Check the keypad-initiated alarms that are in the system by using the Panic keys (or key pairs on some keypads). If a key (or key pair) has been programmed for audible emergency, the keypad will emit a steady alarm sound, and **ALARM** and zone number will be displayed.
If a key (or key pair) has been programmed for silent emergency, there will be no audible alarms or displays, but a report will be sent to the central station.

If a key (or key pair) has been programmed for fire, the keypad and external sounder will emit an interrupted alarm sound, and **ALARM, FIRE** and **zone number** will be displayed.

Silence alarms by entering the security code and pressing [OFF] key.

9. If Output Relay Units have been installed, test their programmed action.
10. Notify the central station when all tests are finished, and verify results with them.

To test the wireless part of the system and the RF Receiver, perform the two following tests: **Transmitter Sniffer Mode** and **Go/NoGo Test Mode**.

Transmitter Sniffer Mode

*Make sure the system is **disarmed** before trying to enter this mode.*

Key **Installer Code + [#] + [3]**. This initiates a procedure that will check that all 5800 Series transmitters have been properly programmed.

NOTE: If the communicator is in the process of sending a report to the central station, the system will not go into the Sniffer mode. If so, wait a few minutes, and try again.

The keypad will display all zone numbers of wireless units programmed into the system. As the system receives a signal from each of the transmitters, the zone number of that transmitter will disappear from the display. The transmitter codes may be checked upon installation, or in an installed system.

All the wireless zone numbers should disappear after about 1-1/2 hours.

NOTE: Any transmitter that is not properly entered into the system will not turn off its zone number.

Exit the Transmitter Sniffer mode by keying **Installer code + [OFF]**.

Go/No Go Test Mode

By keying **Installer code + [#] + [4]**, a mode similar to the test mode is entered, but the wireless receiver gain is reduced. Checking in this mode not only assists in determining good mounting locations for the transmitters when the system is being installed, but also verifies that the RF transmission has sufficient signal amplitude margin for the installed system.

1. Enter the **Installer code + [#] + [4]**.
2. Once transmitters are placed in their desired locations and the approximate length of wire to be run to sensors is connected to the transmitter's screw terminals, fault each transmitter. *Do not conduct this test with your hand wrapped around the transmitter, as this will cause inaccurate results.*
 - The keypad will beep three times to indicate signal reception.
 - If the keypad does not beep, re-orient or move the transmitter to another location. Usually a few inches in either direction is all that is required.
3. Exit the Go/NoGo mode by keying **Installer code + [OFF]**.

TO THE INSTALLER

Regular maintenance and inspection (at least annually) by the installer and frequent testing by the user are vital to continuous satisfactory operation of any alarm system.

The installer should assume the responsibility of developing and offering a regular maintenance program to the user as well as acquainting the user with the proper operation and limitations of the alarm system and its component parts. Recommendations must be included for a specific program of frequent testing (at least weekly) to insure the system's proper operation at all times.

Specifications & Accessories

In This Section

◆ Specifications

◆ Accessories

Specifications

VISTA 10SE Security Control

1. Physical: 12-1/2" W x 14-1/2" H x 3" D (318mm x 368mm x 76mm)

2. Electrical:

VOLTAGE INPUT: 16.5VAC from plug-in 25VA transformer, ADEMCO No. 1321

RECHARGEABLE BACKUP BATTERY: 12VDC, 4AH-17.2AH (Sealed Lead Acid).

Refer to the *FINAL POWER-UP* section to calculate the actual battery size needed.

Charging Voltage: 13.8VDC.

ALARM SOUNDER: 12V, 2.0 Amp output can drive 12V BELLS or can drive one or two 702 (**series** connected) self-contained 20-watt sirens. Do **not** connect two 702s in parallel.

AUXILIARY POWER OUTPUT: 12VDC, 600mA max. (500mA max for UL installations).

Interrupts for 4-wire smoke detector reset.

NOTE: For UL installations, Alarm Sounder plus Auxiliary Power currents must not exceed 600mA total.

STANDBY TIME: (see Table in the *FINAL POWER-UP* section)

FUSE: Battery (3A) No. 90-12.

3. Communication:

Line Seize: Double Pole.

Ringer Equivalence: 0.7B.

FCC Registration No.: AC 398U-68192-AL-E.

6127 and 6128 REMOTE KEYPADS

1. Physical: 5-3/4" W x 4-3/4" H x 1" D (146mm x 121mm x 26mm).

2. Electrical: Voltage Input: 12VDC; Current Drain: 20mA (6127); 30mA (6128)/

6137 REMOTE KEYPAD

1. Physical: 6-1/4" W x 4-3/4" H x 1" D (159mm x 121mm x 26mm).

2. Electrical: Voltage Input: 12VDC; Current Drain: 85mA.

6138 & 6139 REMOTE KEYPADS

1. Physical: 6-1/4" W x 4-3/4" H x 1" D (159mm x 121mm x 26mm).

2. Electrical: Voltage Input: 12VDC; Current Drain: 100mA

Accessories (Compatible Devices)

- No. 1321** 16.5VAC, 25VA Plug-In Transformer (in USA)
No. 1321CN 16.5VAC, 25VA Plug-In Transformer (in Canada)

Sounders

ADEMCO AB-12M 10" Motorized Bell & Box	Motor bell & box. UL Grade A. 100mA current draw.
ADEMCO 1011BE12M 10" Motorized Bell & Box	Motor bell & box. UL Listed. 100mA current draw.
ADEMCO 702 Outdoor Siren	Self-contained 6–12 volt siren (driver built-in) and weatherproof for outdoor use. Can be wired for either a steady or warble sound. 117dB @ 10 feet. 1500mA current draw.
ADEMCO 719 2-Channel Siren	Self-contained 6–12-volt siren (driver built-in). Steady or warble sound. 109dB @ 10 feet. 550mA current draw.
ADEMCO 747 Indoor Siren	Self-contained 6–15 volt siren (driver built-in) for indoor wall mount. 747F available for flush mounting. 105dB @ 10 feet. 400mA current draw.
ADEMCO 747UL Indoor Siren	Self-contained 6–15 volt siren (driver built-in) for indoor wall mount. UL Listed. 85dB @ 10 feet. 320mA current draw.
ADEMCO 744 Siren Driver	6 jumper-selected sound outputs. Rated at 119dB with use of an 8-ohm, 30-watt speaker. 1.3 amps current draw.
ADEMCO 745X3 Voice Siren Driver	12-volt voice siren driver with English, Spanish, and French voice messages. Separate messages for fire and burglary. Use with 8-ohm speaker. UL Listed. 1100mA current draw. NOTE: Requires special power wiring connections.
ADEMCO 705–820, 5-inch Round Speaker	20-watt, 8-ohm indoor or outdoor speaker. Requires a driver.
ADEMCO 713 Speaker	40-watt, 8-ohm, indoor/outdoor speaker. Requires a driver.
System Sensor PA400B (beige)/PA400R (red) Indoor Piezo Sounder	Indoor piezo sounder (red or beige), rated at 90 dB @ 10 feet.

Compatible 4-Wire Smoke/Combustion Detectors

System Sensor

- 1412** 4-wire ionization products of combustion detector.
2412 4-wire photoelectric smoke detector.
2412TH 4-wire photoelectric smoke detector w/135° F (57° C) heat detector.
A77–716B EOL relay module (supervisory module for wired 4-wire fire zone).
2112/24T Low-profile 4-wire photoelectric smoke detector w/135° F (57° C) heat detector.

Regulatory Agency Statements

FEDERAL COMMUNICATIONS COMMISSION (FCC) PART 15 STATEMENT

This equipment has been tested to FCC requirements and has been found acceptable for use. The FCC requires the following statement for your information:

This equipment generates and uses radio frequency energy and if not installed and used properly, that is, in strict accordance with the manufacturer's instructions, may cause interference to radio and television reception. It has been type tested and found to comply with the limits for a Class B computing device in accordance with the specifications in Part 15 of FCC Rules, which are designed to provide reasonable protection against such interference in a residential installation. However, there is no guarantee that interference will not occur in a particular installation. If this equipment does cause interference to radio or television reception, which can be determined by turning the equipment off and on, the user is encouraged to try to correct the interference by one or more of the following measures:

- If using an indoor antenna, have a quality outdoor antenna installed.
- Reorient the receiving antenna until interference is reduced or eliminated.
- Move the radio or television receiver away from the receiver/control.
- Move the antenna leads away from any wire runs to the receiver/control.
- Plug the receiver/control into a different outlet so that it and the radio or television receiver are on different branch circuits.

If necessary, the user should consult the dealer or an experienced radio/television technician for additional suggestions. The user or installer may find the following booklet prepared by the Federal Communications Commission helpful: "Interference Handbook"

This booklet is available from the U.S. Government Printing Office, Washington, DC 20402.

The user shall not make any changes or modifications to the equipment unless authorized by the Installation Instructions or User's Manual. Unauthorized changes or modifications could void the user's authority to operate the equipment.

FEDERAL COMMUNICATIONS COMMISSION (FCC) PART 68 STATEMENT

This equipment complies with Part 68 of the FCC rules. On the front cover of this equipment is a label that contains, among other information, the FCC registration number and ringer equivalence number (REN) for this equipment. If requested, this information must be provided to the telephone company.

This equipment uses the following jacks: An RJ31X is used to connect this equipment to the telephone network.

The REN is used to determine the quantity of devices which may be connected to the telephone line. Excessive RENs on the telephone line may result in the devices not ringing in response to an incoming call. In most, but not all areas, the sum of the RENs should not exceed five (5.0). To be certain of the number of devices that may be connected to the line, as determined by the total RENs, contact the telephone company to determine the maximum REN for the calling area.

If this equipment causes harm to the telephone network, the telephone company will notify you in advance that temporary discontinuance of service may be required. If advance notice is not practical, the telephone company will notify the customer as soon as possible. Also, you will be advised of your right to file a complaint with the FCC if you believe necessary.

The telephone company may make changes in its facilities, equipment, operations, or procedures that could affect the operation of the equipment. If this happens, the telephone company will provide advance notice in order for you to make the necessary modifications in order to maintain uninterrupted service.

If trouble is experienced with this equipment, please contact the manufacturer for repair and warranty information. If the trouble is causing harm to the telephone network, the telephone company may request you remove the equipment from the network until the problem is resolved.

There are no user serviceable components in this product, and all necessary repairs must be made by the manufacturer. Other repair methods may invalidate the FCC registration on this product.

This equipment cannot be used on telephone company-provided coin service. Connection to Party Line Service is subject to state tariffs.

This equipment is hearing-aid compatible.

When programming or making test calls to an emergency number, briefly explain to the dispatcher the reason for the call. Perform such activities in the off-peak hours; such as early morning or late evening.

UL NOTICES

1. This is a "Grade A" residential system.
2. The 4285/4286 VIP Module and 7720PLUS or 7820 Long-Range Radios have not been UL tested and cannot, therefore, be used in a UL installation.
3. The Entry Delay (field *38) cannot be greater than 45 seconds for UL installations.
4. The maximum number of reports per armed period (field *92) must be unlimited (set to 1) for UL installations.
5. Periodic testing (field *49) must be at least every 24 hours (set to 1) for UL installations.
6. Alarm Sounder plus Auxiliary Power currents must not exceed 600mA total for UL installations.
7. Downloading is not permissible for UL installations unless an installer is present at the installation site.

CALIFORNIA STATE FIRE MARSHAL (CSFM) AND UL RESIDENTIAL FIRE 24 HOUR BATTERY BACKUP REQUIREMENTS

The California State Fire Marshal and UL have regulations that require all residential fire alarm control panels to be provided with a backup battery that has sufficient capacity to operate the panel and its attached peripheral devices for 24 hours in the intended standby condition, followed by at least 4 minutes in the intended fire alarm signaling condition.

This control panel can meet these requirements without using a supplementary power supply, provided that the panel's auxiliary power and bell output currents are limited as indicated below.

OUTPUT LIMITATIONS TO MEET CSFM 24 HOUR BATTERY BACKUP REQUIREMENTS AND UL LISTED RESIDENTIAL FIRE INSTALLATIONS			
OUTPUT CURRENT LIMITATIONS		BATTERY INFORMATION	
OUTPUT CURRENT TOTAL	MAXIMUM AUXILIARY CURRENT	BATTERY CAPACITY TO USE (Amp/Hrs)	RECOMMENDED BATTERY (Yuasa Model No.)
600mA maximum total of auxiliary power plus bell output currents	45mA 160mA 200mA 425mA 500mA	4AH 7AH 8AH 14AH 17.2AH	NP4-12 NP7-12 NP4-12 (two)‡ NP7-12 (two)‡ NPG18-12

‡NOTE: Use two batteries, connected in parallel. Obtain an ADEMCO Battery Harness kit. A dual-battery harness is provided with the kit. Both batteries will fit inside the panel's cabinet.

Limitations and Warranties

WARNING

THE LIMITATIONS OF THIS ALARM SYSTEM

While this System is an advanced design security system, it does not offer guaranteed protection against burglary, fire or other emergency. Any alarm system, whether commercial or residential, is subject to compromise or failure to warn for a variety of reasons. For example:

- Intrusion detectors (e.g., passive infrared detectors), smoke detectors, and many other sensing devices will not work without power. Battery-operated devices will not work without batteries, with dead batteries, or if the batteries are not put in properly. Devices powered solely by AC will not work if their AC power supply is cut off for any reason, however briefly.
- Signals sent by wireless transmitters may be blocked or reflected by metal before they reach the alarm receiver. Even if the signal path has been recently checked during a weekly test, blockage can occur if a metal object is moved into the path.
- A user may not be able to reach a panic or emergency button quickly enough.
- While smoke detectors have played a key role in reducing residential fire deaths in the United States, they may not activate or provide early warning for a variety of reasons in as many as 35% of all fires, according to data published by the Federal Emergency Management Agency. Some of the reasons smoke detectors used in conjunction with this System may not work are as follows. Smoke detectors may have been improperly installed and positioned. Smoke detectors may not sense fires that start where smoke cannot reach the detectors, such as in chimneys, in walls, or roofs, or on the other side of closed doors. Smoke detectors also may not sense a fire on another level of a residence or building. A second floor detector, for example, may not sense a first floor or basement fire. Finally, smoke detectors have sensing limitations. No smoke detector can sense every kind of fire every time. In general, detectors may not always warn about fires caused by carelessness and safety hazards like smoking in bed, violent explosions, escaping gas, improper storage of flammable materials, overloaded electrical circuits, children playing with matches, or arson. Depending on the nature of the fire and/or location of the smoke detectors, the detector, even if it operates as anticipated, may not provide sufficient warning to allow all occupants to escape in time to prevent injury or death.
- Passive Infrared Motion Detectors can only detect intrusion within the designed ranges as diagrammed in their installation manual. Passive Infrared Detectors do not provide volumetric area protection. They do create multiple beams of protection, and intrusion can only be detected in unobstructed areas covered by those beams. They cannot detect motion or intrusion that takes place behind walls, ceilings, floors, closed doors, glass partitions, glass doors, or windows. Mechanical tampering, masking, painting or spraying of any material on the mirrors, windows or any part of the optical system can reduce their detection ability. Passive Infrared Detectors sense changes in temperature; however, as the ambient temperature of the protected area approaches the temperature range of 90° to 105°F (32° to 40°C), the detection performance can decrease.
- Alarm warning devices such as sirens, bells or horns may not alert people or wake up sleepers if they are located on the other side of closed or partly open doors. If warning devices are located on a different level of the residence from the bedrooms, then they are less likely to waken or alert people inside the bedrooms. Even persons who are awake may not hear the warning if the alarm is muffled by noise from a stereo, radio, air conditioner or other appliance, or by passing traffic. Finally, alarm warning devices, however loud, may not warn hearing-impaired people.
- Telephone lines needed to transmit alarm signals from a premises to a central monitoring station may be out of service or temporarily out of service. Telephone lines are also subject to compromise by sophisticated intruders.
- Even if the system responds to the emergency as intended, however, occupants may have insufficient time to protect themselves from the emergency situation. In the case of a monitored alarm system, authorities may not respond appropriately.
- This equipment, like other electrical devices, is subject to component failure. Even though this equipment is designed to last as long as 20 years, the electronic components could fail at any time.

The most common cause of an alarm system not functioning when an intrusion or fire occurs is inadequate maintenance. This alarm system should be tested weekly to make sure all sensors and transmitters are working properly. The security keypad (and remote keypad) should be tested as well.

Wireless transmitters (used in some systems) are designed to provide long battery life under normal operating conditions. Longevity of batteries may be as much as 4 to 7 years, depending on the environment, usage, and the specific wireless device being used. External factors such as humidity, high or low temperatures, as well as large swings in temperature, may all reduce the actual battery life in a given installation. This wireless system, however, can identify a true low battery situation, thus allowing time to arrange a change of battery to maintain protection for that given point within the system.

Installing an alarm system may make the owner eligible for a lower insurance rate, but an alarm system is not a substitute for insurance. Homeowners, property owners and renters should continue to act prudently in protecting themselves and continue to insure their lives and property.

We continue to develop new and improved protection devices. Users of alarm systems owe it to themselves and their loved ones to learn about these developments.

ADEMCO LIMITED WARRANTY

Alarm Device Manufacturing Company, a Division of Pittway Corporation, and its divisions, subsidiaries and affiliates ("Seller"), 165 Eileen Way, Syosset, New York 11791, warrants its products to be in conformance with its own plans and specifications and to be free from defects in materials and workmanship under normal use and service for 24 months from the date stamp control on the product or, for products not having an ADEMCO date stamp, for 12 months from date of original purchase unless the installation instructions or catalog sets forth a shorter period, in which case the shorter period shall apply. Seller's obligation shall be limited to repairing or replacing, at its option, free of charge for materials or labor, any product which is proved not in compliance with Seller's specifications or proves defective in materials or workmanship under normal use and service. Seller shall have no obligation under this Limited Warranty or otherwise if the product is altered or improperly repaired or serviced by anyone other than ADEMCO factory service. For warranty service, return product transportation prepaid, to ADEMCO Factory Service, 165 Eileen Way, Syosset, New York 11791.

THERE ARE NO WARRANTIES, EXPRESS OR IMPLIED, OF MERCHANTABILITY, OR FITNESS FOR A PARTICULAR PURPOSE OR OTHERWISE, WHICH EXTEND BEYOND THE DESCRIPTION ON THE FACE HEREOF. IN NO CASE SHALL SELLER BE LIABLE TO ANYONE FOR ANY CONSEQUENTIAL OR INCIDENTAL DAMAGES FOR BREACH OF THIS OR ANY OTHER WARRANTY, EXPRESS OR IMPLIED, OR UPON ANY OTHER BASIS OF LIABILITY WHATSOEVER, EVEN IF THE LOSS OR DAMAGE IS CAUSED BY THE SELLER'S OWN NEGLIGENCE OR FAULT.

Seller does not represent that the products it sells may not be compromised or circumvented; that the products will prevent any personal injury or property loss by burglary, robbery, fire or otherwise; or that the products will in all cases provide adequate warning or protection. Customer understands that a properly installed and maintained alarm may only reduce the risk of a burglary, robbery, fire or other events occurring without providing an alarm, but it is not insurance or a guarantee that such will not occur or that there will be no personal injury or property loss as a result. CONSEQUENTLY, SELLER SHALL HAVE NO LIABILITY FOR ANY PERSONAL INJURY, PROPERTY DAMAGE OR OTHER LOSS BASED ON A CLAIM THE PRODUCT FAILED TO GIVE WARNING. HOWEVER, IF SELLER IS HELD LIABLE, WHETHER DIRECTLY OR INDIRECTLY, FOR ANY LOSS OR DAMAGE ARISING UNDER THIS LIMITED WARRANTY OR OTHERWISE, REGARDLESS OF CAUSE OR ORIGIN, SELLER'S MAXIMUM LIABILITY SHALL NOT IN ANY CASE EXCEED THE PURCHASE PRICE OF THE PRODUCT, WHICH SHALL BE THE COMPLETE AND EXCLUSIVE REMEDY AGAINST SELLER. This warranty replaces any previous warranties and is the only warranty made by Seller on this product. No increase or alteration, written or verbal, of the obligations of this Limited Warranty is authorized.

Canadian Department Of Communications (DOC) Statement

NOTICE

The Canadian Department of Communications label identifies certified equipment. This certification means that the equipment meets certain telecommunications network protective, operational and safety requirements. The Department does not guarantee the equipment will operate to the user's satisfaction.

Before installing this equipment, users should ensure that it is permissible to be connected to the facilities of the local telecommunications company. The equipment must also be installed using an acceptable method of connection. In some cases, the company's inside wiring associated with a single-line individual service may be extended by means of certified connector assembly (telephone extension cord). The customer should be aware that compliance with the above conditions may not prevent degradation of service in some situations.

Repairs to certified equipment should be made by an authorized Canadian maintenance facility designated by the supplier. Any repairs or alterations made by the user to this equipment, or equipment malfunctions, may give the telecommunications company cause to request the user to disconnect the equipment.

Users should ensure for their own protection that the electrical ground connections of the power utility, telephone lines and internal metallic water pipe system, if present, are connected together. This precaution may be particularly important in rural areas.

Caution: Users should not attempt to make such connections themselves, but should contact the appropriate electric inspection authority, or electrician, as appropriate.

The Load Number (LN) assigned to each terminal device denotes the percentage of the total load to be connected to a telephone loop which is used by the device, to prevent overloading. The termination on a loop may consist of any combination of devices subject only to the requirement that the total of the Load Numbers of all the devices does not exceed 100.

AVIS

L'étiquette du ministère des Communications du Canada identifie le matériel homologué. Cette étiquette certifie que le matériel est conforme à certaines normes de protection, d'exploitation et de sécurité des réseaux de télécommunications. Le ministère n'assure toutefois pas que le matériel fonctionnera à la satisfaction de l'utilisateur.

Avant d'installer ce matériel, l'utilisateur doit s'assurer qu'il est permis de le raccorder aux installations de l'entreprise locale de télécommunications. Le matériel doit également être installé en suivant une méthode acceptée de raccordement. Dans certains cas, les fils intérieurs de l'entreprise utilisés pour un service individuel à la ligne unique peuvent être prolongés au moyen d'un dispositif homologué de raccordement (cordon prolongateur téléphonique interne). L'abonné ne doit pas oublier qu'il est possible que la conformité aux conditions énoncées ci-dessus n'empêche pas la dégradation du service dans certaines situations. Actuellement, les entreprises de télécommunications ne permettent pas que l'on raccorde leur matériel aux prises d'abonnés, sauf dans les cas précis prévus par les tarifs particuliers de ces entreprises.

Les réparations du matériel homologué doivent être effectuées par un centre d'entretien canadien autorisé désigné par le fournisseur. La compagnie de télécommunications peut demander à l'utilisateur de débrancher un appareil à la suite de réparations ou de modifications effectuées par l'utilisateur ou à cause de mauvais fonctionnement.

Pour sa propre protection, l'utilisateur doit s'assurer que tous les fils de mise en terre de la source d'énergie électrique, des lignes téléphoniques de réseau de conduites d'eau s'il y en a, soient raccordés ensemble. Cette précaution est particulièrement importante dans les régions rurales.

Avertissement: L'utilisateur ne doit pas tenter de faire ces raccordements lui-même il doit avoir recours à un service d'inspection des installations électriques, ou à un électricien, selon le cas. L'indice de charge (IC) assigné à chaque dispositif terminal pour éviter toute surcharge indique le pourcentage de la charge totale qui peut être raccordé à un circuit téléphonique bouclé utilisé par ce dispositif. La terminaison du circuit bouclé peut être constituée de n'importe quelle combinaison de dispositifs, pourvu que la somme des indices de charge de l'ensemble des dispositifs ne dépasse pas 100.

Figure 17. VISTA-105E SUMMARY OF CONNECTIONS DIAGRAM

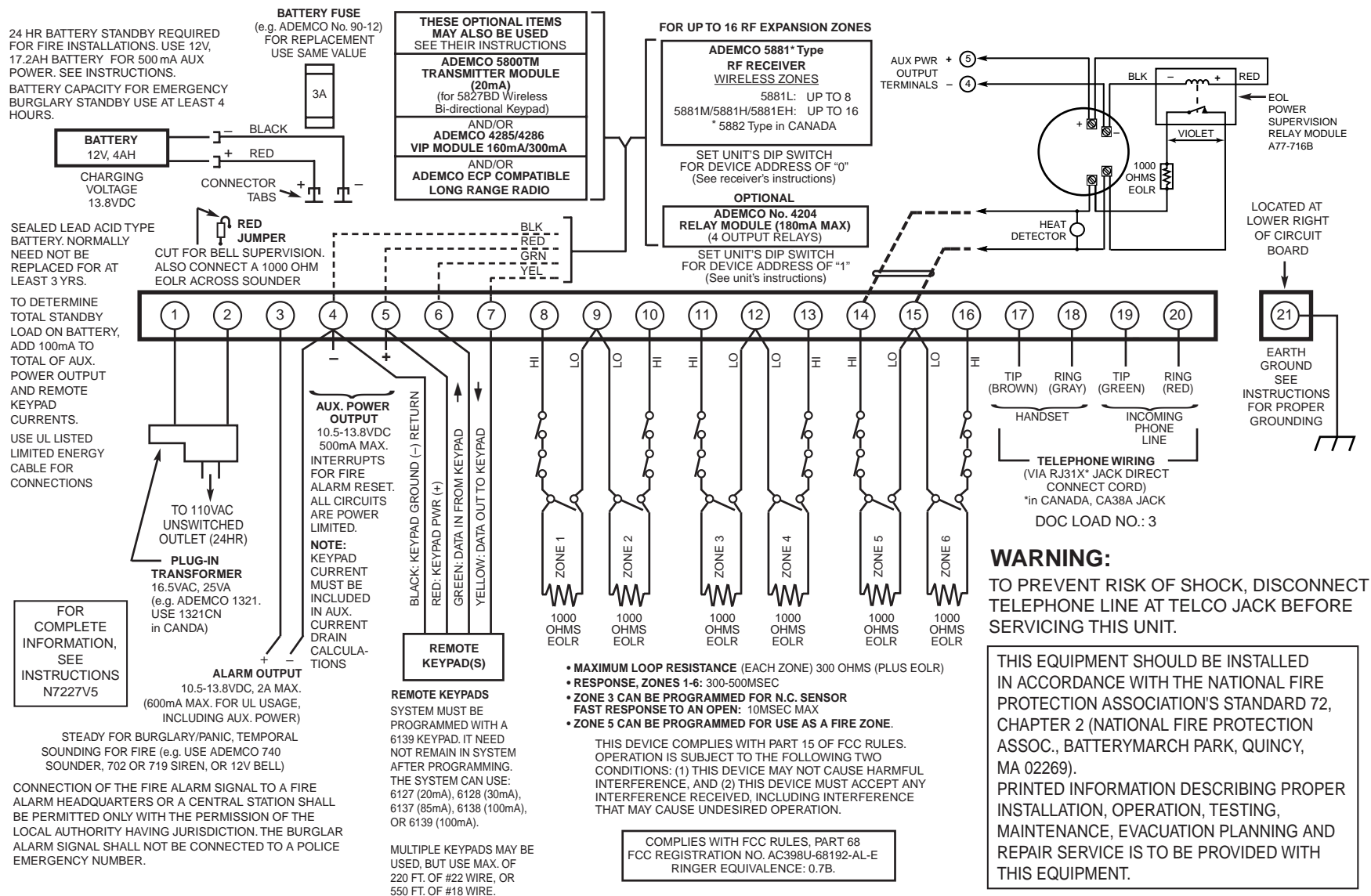

WARNING: OWNER'S INSTRUCTION NOTICE NOT TO BE REMOVED. WEEKLY TESTING IS REQUIRED TO ENSURE PROPER OPERATION OF THIS SYSTEM.

ADEMCO
GROUP

165 Eileen Way, Syosset, New York 11791

Copyright © 2000 PITTWAY CORPORATION



N7227V5 10/00